

Product Specifications

| | |
|--------------------|---------------------------|
| Customer | Standard |
| Description | 1.9" TFT EPD Panel |
| Model Name | E2190CS021 |
| Date | 2020/12/28 |
| Doc. No. | 1P133-00 |
| Revision | 03 |

| | |
|---|--|
| Customer Approval | |
| | |
| Date | |
| The above signature represents that the product specifications, testing regulation, and warranty in the specifications are accepted | |

| | | | |
|--|---|---|---|
| | Design Engineering | | |
| | Approval | Check | Design |
| |  |  |  |

4F, No. 28, Chuangye Rd., Tainan Science Park, Tainan City 74144, Taiwan (R.O.C.)

Tel: +886-6-279-5399

Fax: +886-6-505-5300

Copyright

Pervasive Displays Incorporated All rights reserved.

This document is the exclusive property of Pervasive Displays Inc. (PDI) and shall not be reproduced or copied or transformed to any other format without prior permission of PDI. (PDI Confidential)

本資料為龍亭新技股份有限公司專有之財產，非經許可，不得複製、翻印或轉變成其他形式使用。

龍亭新技股份有限公司 Pervasive Displays Inc.

4F, No. 28, Chuangye Rd., Tainan Science Park, Tainan City 74144, Taiwan (R.O.C.)

Tel: +886-6-279-5399

<http://www.pervasivedisplays.com>

Table of Contents

| | |
|--|----|
| Revision History..... | 6 |
| Glossary of Acronyms..... | 7 |
| 1 General Description..... | 8 |
| 1.1 Overview..... | 8 |
| 1.2 Features..... | 8 |
| 1.3 Applications..... | 8 |
| 1.4 General Specifications..... | 9 |
| 1.5 Mechanical Specifications..... | 10 |
| 2 Absolute Maximum Ratings..... | 11 |
| 2.1 Absolute Ratings of Environment..... | 11 |
| 2.2 Reliability Test Item..... | 12 |
| 2.3 Product Lifetime..... | 12 |
| 2.4 Product Warranty..... | 12 |
| 3 Electrical Characteristics..... | 13 |
| 3.1 Absolute Maximum Ratings of Panel..... | 13 |
| 3.2 Recommended Operation Conditions of Panel..... | 13 |
| 4 Application Circuit Block Diagram..... | 15 |
| 5 Terminal Pin Assignment & Reference Circuit..... | 16 |
| 5.1 Terminal Pin Assignment..... | 16 |
| 5.2 Reference Circuit..... | 18 |
| 6 Optical Characteristics..... | 19 |
| 6.1 Test Conditions..... | 19 |
| 6.2 Optical Specifications..... | 19 |
| 6.2.1 Optical..... | 19 |
| 6.2.2 Ghosting..... | 22 |
| 7 Packing..... | 23 |
| 8 Precautions..... | 25 |
| 9 Definition of Labels..... | 27 |

List of Figures

| | | |
|------------|---|----|
| Figure 1-1 | EPD Drawing | 10 |
| Figure 3-1 | Test Pattern of Panel | 14 |
| Figure 3-2 | Image Update Current Profile | 14 |
| Figure 3-3 | Current Measurement | 14 |
| Figure 4-1 | Application Circuit Block Diagram..... | 15 |
| Figure 5-1 | EPD Reference Circuit | 18 |
| Figure 6-1 | Optical measurement..... | 20 |
| Figure 6-2 | Definition of Viewing Angle to Measure Contrast Ratio | 21 |
| Figure 7-1 | Packing Diagram | 23 |
| Figure 9-1 | Definition of Model Labels | 27 |
| Figure 9-2 | Carton Label..... | 27 |
| Figure 9-3 | Pallet Label | 28 |

List of Tables

| | | |
|-----------|--|----|
| Table 1-1 | General Specification..... | 9 |
| Table 2-1 | Absolute Ratings of Environment..... | 11 |
| Table 2-2 | Reliability Test Items..... | 12 |
| Table 3-1 | Absolute Maximum Ratings of Panel..... | 13 |
| Table 3-2 | Recommended Operation Conditions of Panel..... | 13 |
| Table 5-1 | FPC Specification..... | 16 |
| Table 5-2 | Terminal Pin Assignment..... | 16 |
| Table 6-1 | Optical Measurement Conditions..... | 19 |
| Table 6-2 | Optical Measurement with D65 light source..... | 19 |
| Table 6-3 | Measurement of Ghosting..... | 22 |

Revision History

| Version | Date | Page (New) | Section | Description |
|---------|------------|------------------------------|-----------------------------|--|
| Ver.01 | 2016/12/16 | All | All | Product specification first issued. |
| Ver.02 | 2017/12/14 | 28 29 | 9 | Figure 9-1: label size change to 25*12mm Figure 9-2: linear code change to 2D code & 23 digits change to 28 digits Figure 9-3: carton label 6 digits change to 8 digits |
| Ver.03 | 2020/12/28 | 9 10-11 17 24 28 | 1.4 1.5 5.1 7 9 | 1. Table 1-1 add "weight" 2. delete Table 1-2, please refer to Mechanical drawing Move Table 1-3 to Table 5-1 3. update Figure 1-5 Mechanical drawing 4. update Figure 7-1 packing Diagram 5. delete Figure 9-1, please refer to Mechanical drawing 6. delete Figure 9-2, 1D code definition |
| | | | | |

Glossary of Acronyms

| | |
|------------|---|
| EPD | Electrophoretic Display (e-Paper Display) |
| EPD Panel | EPD |
| EPD Module | EPD with TCon board |
| TCon | Timing Controller |
| TFT | Thin Film Transistor |
| MCU | Microcontroller Unit |
| FPC | Flexible Printed Circuit |
| FPL | Front Plane Laminate |
| SPI | Serial Peripheral Interface |
| COG | Chip on Glass |
| IIS | Incoming Inspection Standard |
| ISTA | International Safe Transit Association |
| PDI | Pervasive Displays Incorporated |

1 General Description

1.1 Overview

This is a 1.9" a-Si, active matrix TFT, Electronic Paper Display (EPD) panel. The panel has such high resolution (101.6dpi) that it is able to easily display fine patterns. Due to its bi-stable nature, the EPD panel requires very little power to update and needs no power to maintain an image.

1.2 Features

- a-Si TFT active matrix Electronic Paper Display(EPD)
- Resolution: 144 x 128
- Ultra low power consumption
- Super Wide Viewing Angle - near 180°
- Extra thin & light
- SPI interface
- RoHS compliant

1.3 Applications

- Electronic shelf label (ESL)
- Reusable container
- Badge

1.4 General Specifications

Table 1-1 General Specification

| Item | Specification | Unit | Note |
|-------------------|----------------------------|-------|------|
| Outline Dimension | 42.0(H) x 42.9(V) x 1.0(T) | mm | (1) |
| Active Area | 36.0(H) x 32.0(V) | mm | |
| Driver Element | a-Si TFT active matrix | - | |
| FPL | Aurora Mb | - | |
| Pixel Number | 144 x 128 | pixel | |
| Pixel Pitch | 0.250 x 0.250 (101.6dpi) | mm | |
| Pixel Arrangement | Vertical stripe | - | |
| Display Colors | Black/White | - | |
| Surface Treatment | Anti-Glare | - | |
| Driver IC | G2 | - | - |
| Weight | 3.5±1 | G | - |

Note (1): Not including the FPC.

1.5 Mechanical Specifications

Figure 1-1 EPD Drawing

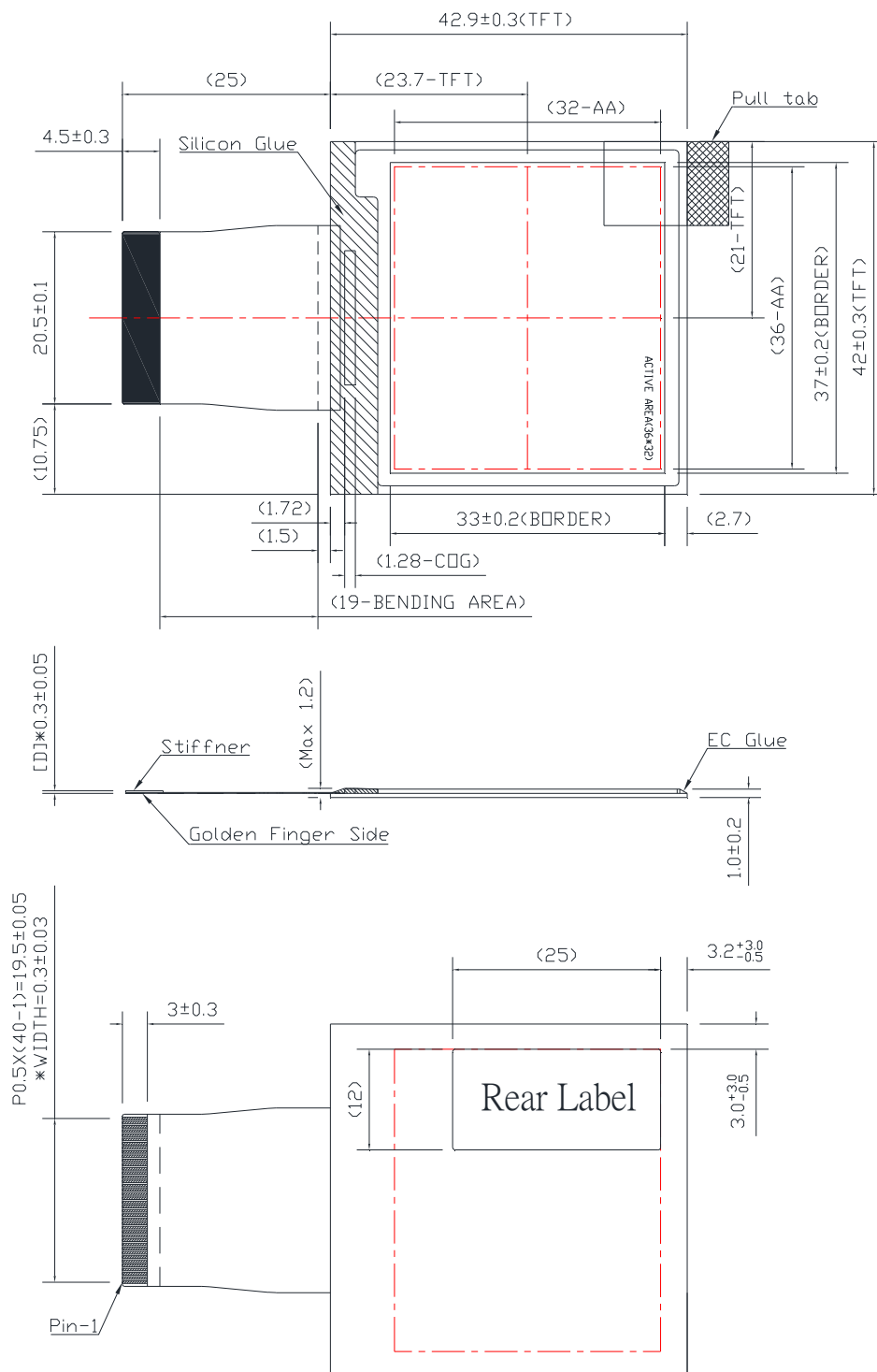

General tolerance: ± 0.3 mm

2 Absolute Maximum Ratings

2.1 Absolute Ratings of Environment

Table 2-1 Absolute Ratings of Environment

| Item | Symbol | Value | | Unit | Note |
|-------------------------------|------------------|-------|------|------|-------------|
| | | Min. | Max. | | |
| Storage Temperature | T _{ST} | -20 | +60 | °C | (1),(3) |
| Storage Humidity | H _{ST} | 30 | 90 | %RH | (1),(3) |
| Operating Ambient Temperature | T _{OP} | 0 | +50 | °C | (1),(2),(4) |
| Operating Ambient Humidity | H _{OP} | 30 | 90 | %RH | (1),(2),(4) |
| Optimal Storage Temperature | T _{STo} | -10 | 35 | °C | (1),(3) |
| Optimal Storage Humidity | H _{STo} | 40 | 60 | %RH | (1),(3) |

Note (1):

- (a) 90 %RH Max. ($T_a \leq 40$ °C), where T_a is ambient temperature.
- (b) Wet-bulb temperature should be 39 °C Max. ($T_a > 40$ °C).
- (c) No condensation and no frost in absolute ratings of Environment.

Note (2): The temperature of panel display surface area should be 0 °C Min. and 50 °C Max. Refresh time depends on operation temperature.

Note (3): E Ink Material is Moisture and UV sensitive. The absolute rating operating environments describes the boundary conditions for updating the display while the absolute rating storage environment describe the boundary conditions for a display not updating. While displays are rated to perform according to specification for the warranty period at the absolute specified operating environment, the better the storage condition, the better the E Ink displays will perform. Similar to other moisture and UV sensitive components, we recommend that our displays be stored in temperature and humidity control environments, and whenever possible, under above defined Optimal Storage Condition, away from sunlight, to optimize their performance.

Note (4): The performance of EPD may be degraded under sunlight. Please customer consults PDI if customer wants to use EPD under sunlight.

2.2 Reliability Test Item

Table 2-2 Reliability Test Items

| Item | Test Condition | Remark |
|-------------------------------------|---|-----------|
| High Temperature Operation | 50 °C / 30 %RH for 240h | (1) (2) |
| Low Temperature Operation | 0 °C for 240h | (1) (2) |
| High Temperature/Humidity Operation | 40 °C / 90 %RH for 240h | (1) (2) |
| High Temperature Storage | 60 °C / 30%RH for 240h | (1)(2)(3) |
| Low Temperature Storage | -20 °C for 240h | (1)(2)(3) |
| High Temperature/Humidity Storage | 60 °C / 80 %RH for 240h | (1)(2)(3) |
| Thermal Cycles (Non-operation) | 1 Cycle:-20°C/30min → 60°C/30min, for 100 Cycles | (1)(2)(3) |
| Package Drop Test | Drop from 97cm. (ISTA) 1 corner, 3 edges, 6 sides. One drop for each. | (1)(2)(3) |
| Package Random Vibration Test | 1.15Grms, 1Hz ~ 200Hz. (ISTA) | (1)(2)(3) |

Note (1): No condensation and no frost during test. End of test, function, mechanical, and optical shall be satisfied with product specification and IIS.

Note (2): The test result and judgment are based on PDI's 1bit driving waveform, driving fixture and driving system.

Note (3): Stay white pattern for storage and non-operation test.

2.3 Product Lifetime

The EPD Module is designed for a 5-year life-time with 25 °C/50%RH operation assumption. Reliability estimation testing with accelerated life-time theory would be demonstrated to provide confidence of EPD lifetime.

2.4 Product Warranty

Warranty conditions have to be negotiated between PDI and individual customers. PDI provides 13months warranty for all products which are purchased from PDI.

3 Electrical Characteristics

3.1 Absolute Maximum Ratings of Panel

Table 3-1 Absolute Maximum Ratings of Panel

| Parameter | Symbol | Value | | Unit | Note |
|---------------|-----------------|-------|-----|------|-----------------------------------|
| | | Min | Max | | |
| Digital Power | V _{DD} | -0.3 | 6.0 | V | |
| Analog Power | V _{CC} | -0.3 | 6.0 | V | |
| Ground | V _{SS} | - | | - | Connect V _{SS} to Ground |

T_a = 25 ± 2 °C

3.2 Recommended Operation Conditions of Panel

Table 3-2 Recommended Operation Conditions of Panel

| Parameter | Symbol | Value | | | Unit | Note |
|-----------------------|-----------------------------------|-----------------|--------------------|-----|--------------------|-----------------------------------|
| | | Min | Typ | Max | | |
| Digital Power | V _{DD} | 2.3 | 3.0 | 3.6 | V | |
| Analog Power | V _{CC} | 2.3 | 3.0 | 3.6 | V | |
| Input Voltage | High | V _{IH} | 0.8V _{DD} | - | V _{DD} | /CS, ID, SCLK, SI, /RESET |
| | Low | V _{IL} | V _{SS} | - | 0.2V _{DD} | |
| Output Voltage | High | V _{OH} | 0.8V _{DD} | - | V _{DD} | I _{OH} =0.5mA, SO, BUSY |
| | Low | V _{OL} | V _{SS} | - | 0.2V _{DD} | I _{OL} =-0.5mA, SO, BUSY |
| Input Leakage Current | High | I _{IH} | - | - | 2.0 | uA |
| | Low | I _{IL} | - | - | -2.0 | uA |
| Input Current | I _{DD} + I _{CC} | - | 4 | 8 | mA | (1),(2),(3) |
| DC/DC Inrush Current | I _{PEAK} | - | 30 | 90 | mA | (1),(2),(3) |

T_a = 25 ± 2 °C

Note (1):

Figure 3-1 Test Pattern of Panel



These currents are tested with PDI test jig.

Note (2):

$V_{DD}=V_{CC}=3.0V$

Figure 3-2 Image Update Current Profile

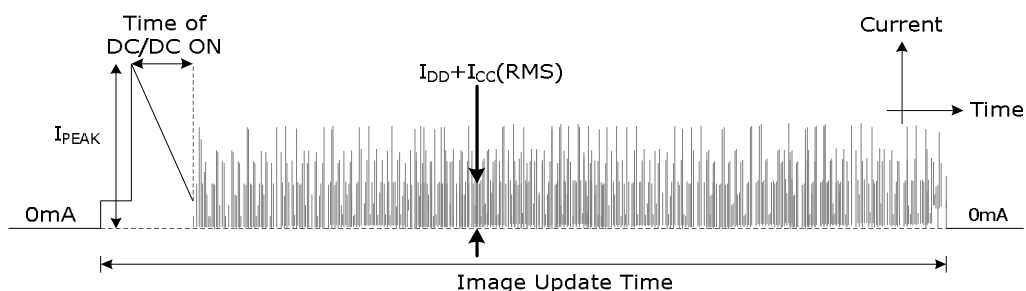

The "Time of DC/DC ON" which contains the some current peak of $V_{GH}/V_{DH}/V_{GL}/V_{DL}/V_{COM}$.

Note (3):

Figure 3-3 Current Measurement

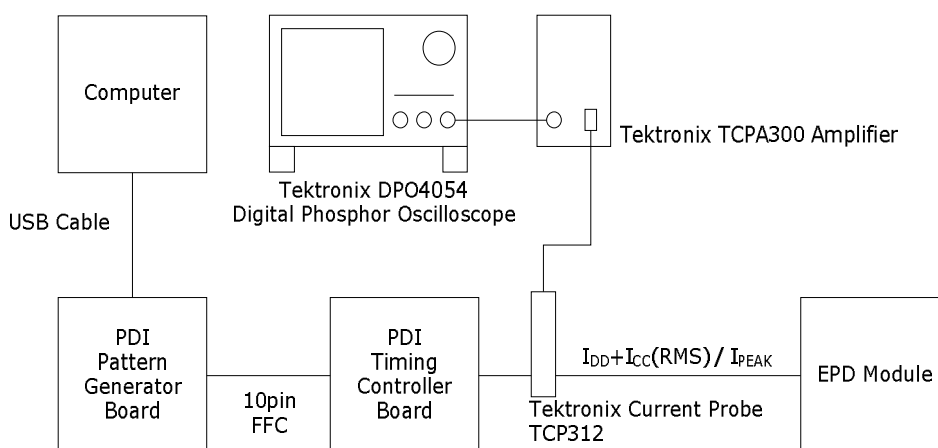

4 Application Circuit Block Diagram

Figure 4-1 Application Circuit Block Diagram

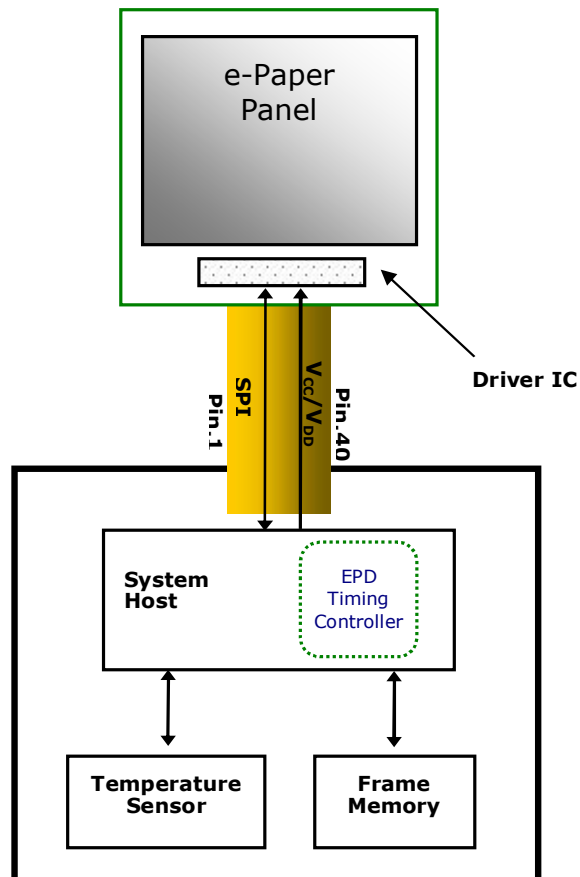

5 Terminal Pin Assignment & Reference Circuit

5.1 Terminal Pin Assignment

Table 5-1 FPC Specification

| Item | Pin numbers | Pitch (mm) | Connector | Note |
|---------------|-------------|------------|---|------|
| Golden Finger | 40 | 0.5 | STARCONN 089H40 or HRS TF31-40S or Compatible | |

Table 5-2 Terminal Pin Assignment

| No. | Signal | Type | Connected to | Function |
|-----|--------|------|-----------------------|--|
| 1 | /CS | I | Tcon | Chip Select. Low enable |
| 2 | BUSY | O | Tcon | When BUSY = HIGH, EPD stays in busy state that EPD ignores any input data from SPI |
| 3 | ID | I | Ground | Connect ID to ground |
| 4 | SCLK | I | Tcon | Clock for SPI |
| 5 | SI | I | Tcon | Serial input from Timing Controller to EPD |
| 6 | SO | O | Tcon | Serial output from EPD to Timing Controller |
| 7 | /RESET | I | Tcon | Reset signal. Low enable |
| 8 | PWRON | - | NC | Keep open |
| 9 | VCL | C | Capacitor | |
| 10 | C42P | - | NC | Not Connected |
| 11 | C42M | - | | |
| 12 | C41P | C | Charge-Pump Capacitor | |
| 13 | C41M | C | | |
| 14 | C31M | C | Charge-Pump Capacitor | |
| 15 | C31P | C | | |
| 16 | C21M | C | Charge-Pump | |

| | | | | |
|----|-------------------------|----|------------------------|--|
| 17 | C21P | C | Capacitor | |
| 18 | C16M | C | Charge-Pump Capacitor | |
| 19 | C16P | C | | |
| 20 | C15M | C | Charge-Pump Capacitor | |
| 21 | C15P | C | | |
| 22 | C14M | C | Charge-Pump Capacitor | |
| 23 | C14P | C | | |
| 24 | C13M | C | Charge-Pump Capacitor | |
| 25 | C13P | C | | |
| 26 | C12M | C | Charge-Pump Capacitor | |
| 27 | C12P | C | | |
| 28 | C11M | C | Charge-Pump Capacitor | |
| 29 | C11P | C | | |
| 30 | V _{COM_DRIVER} | RC | Resistor & Capacitor | The signal duty cycle can drive V _{COM} voltage from source driver IC |
| 31 | V _{CC} | P | V _{CC} | Power supply for analog part of source driver |
| 32 | V _{DD} | P | V _{DD} | Power supply for digital part of source driver |
| 33 | V _{SS} | P | Ground | |
| 34 | V _{GH} | C | Capacitor | |
| 35 | V _{GL} | C | Capacitor | |
| 36 | V _{DH} | C | Capacitor | |
| 37 | V _{DL} | C | Capacitor | |
| 38 | BORDER | - | - | Not connected |
| 39 | V _{ST} | P | V _{COM_PANEL} | |
| 40 | V _{COM_PANEL} | C | Capacitor | V _{COM} to panel |

Note:

Type: I: Input O: Output
 C: Capacitor RC: Resistor and Capacitor
 P: Power

5.2 Reference Circuit

Figure 5-1 EPD Reference Circuit

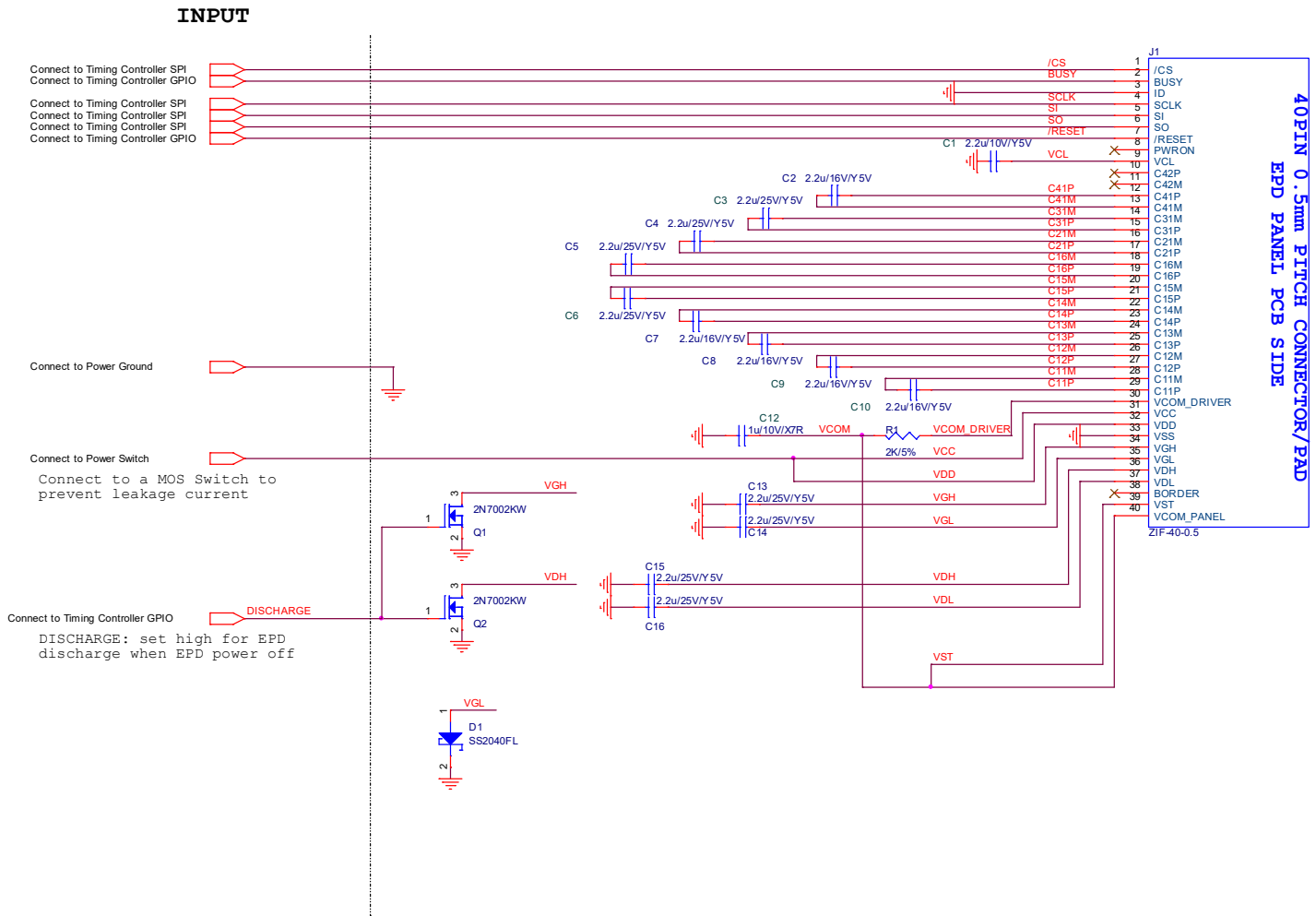

Note: (1) V_{DD} and V_{CC} must be discharged promptly after power off.

6 Optical Characteristics

6.1 Test Conditions

Table 6-1 Optical Measurement Conditions

| Item | Symbol | Value | Unit |
|---------------------|-----------------------------------|-------|------|
| Ambient Temperature | Ta | 25±2 | °C |
| Ambient Humidity | Ha | 50±10 | %RH |
| Supply Voltage | V _{CC} & V _{DD} | 3.0 | V |

Note: Measure optical at RT (Room Temperature) after pattern update at 25 °C.

6.2 Optical Specifications

6.2.1 Optical

Table 6-2 Optical Measurement with D65 light source

| Item | Symbol | Rating | | | Unit | Note |
|----------------|--------|--------|------|------|------|--|
| | | Min. | Typ. | Max. | | |
| Contrast ratio | CR | - | 12:1 | - | - | $\theta_x=\theta_y=0$ (1),(2),(4),(5) |
| Refresh time | Tr | - | 2 | - | sec | (1),(3),(5) |
| White state | L* | - | 70 | - | - | $\theta_x=\theta_y=0$ (1),(2),(5) |
| | a* | | -2.6 | | | |
| | b* | - | -0.7 | - | | |
| Reflectance | R% | - | 41 | - | % | (1),(2),(5) |

Note (1): Panel is driven by PDI waveform without masking film and optical measurement by CM-700D with D65 light source and SCE mode.

Figure 6-1 Optical measurement

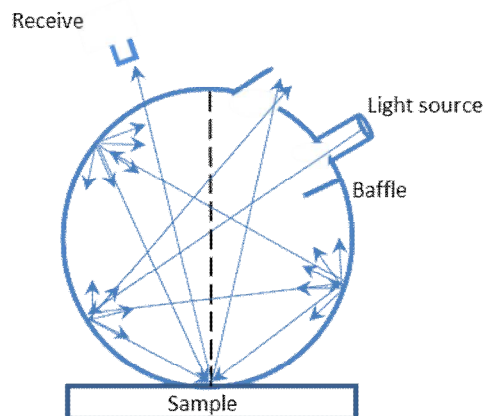
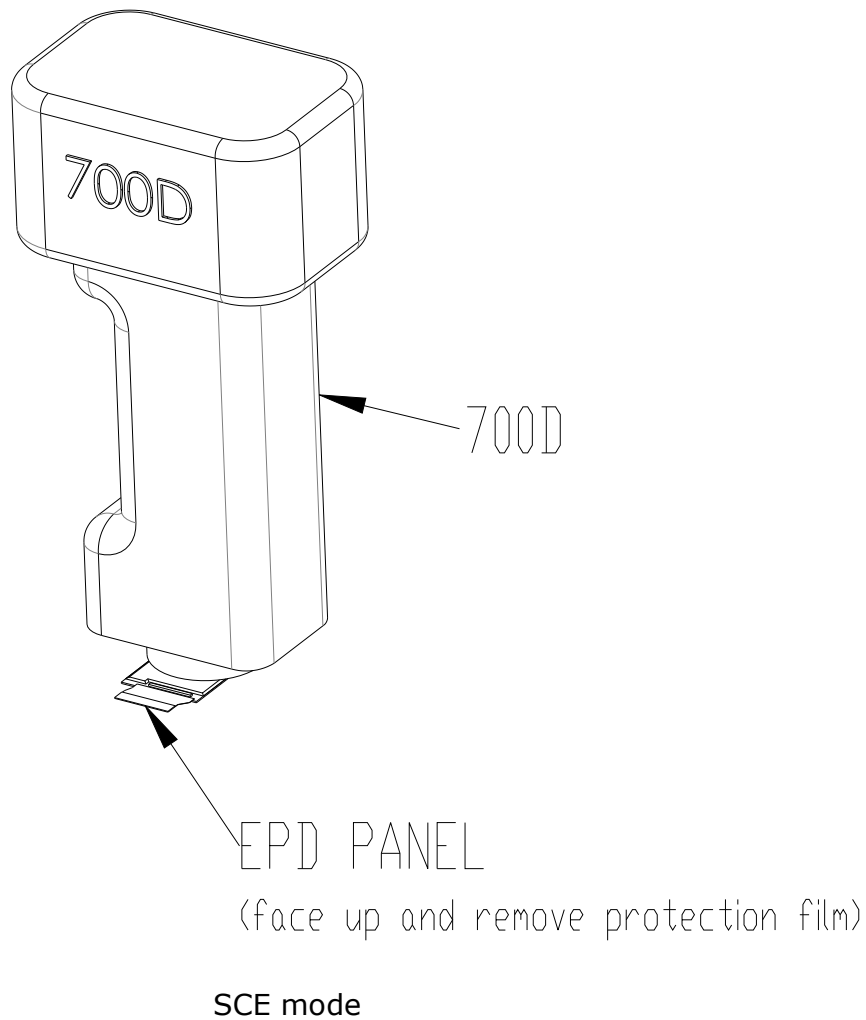

Note (2): Definition of Viewing Angle (θ_x, θ_y):

Figure 6-2 Definition of Viewing Angle to Measure Contrast Ratio

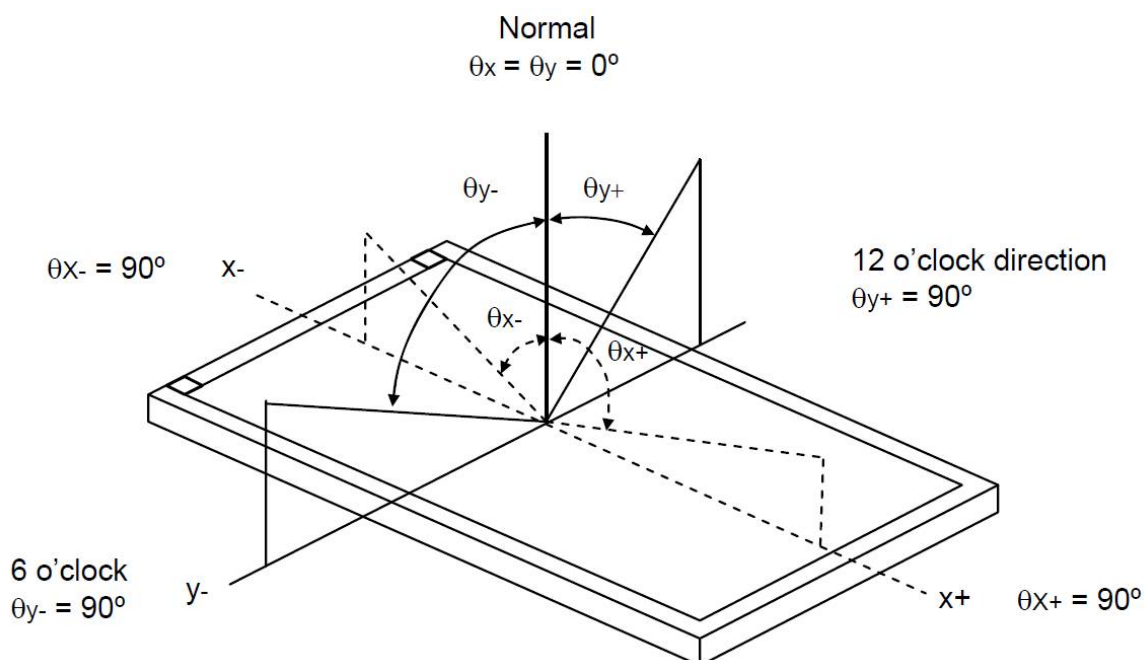

Note (3): Refresh time is the time that e-paper particles move not including the power on and off time. The refresh time is measured at 25°C. The refresh time and contrast ratio varies due to different films, display performance requirements, and ambient temperatures.

Note (4): Contrast ratio (C.R.): The Contrast ratio is calculated by the following expression. $C.R. = (R\% \text{ White}) / (R\% \text{ Black})$.

Note (5): Optical data is measured at 60 seconds after refresh with PDI's global update procedure.

6.2.2 Ghosting

Below are two test methods to verify if ghosting is within an acceptable range. Test 1 and Test 2 use measured data to calculate color different, ΔE_{00} (CIEDE 2000).

The condition of measurement is to follow " Table 6-1 Optical Measurement Conditions".

- Test 1: White to Black Ghosting

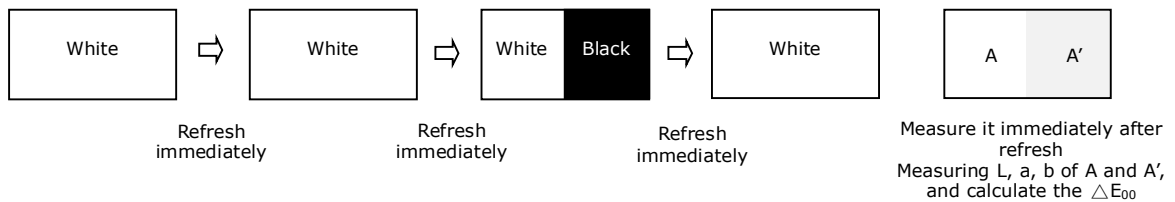

- Test 2: Black to White Ghosting

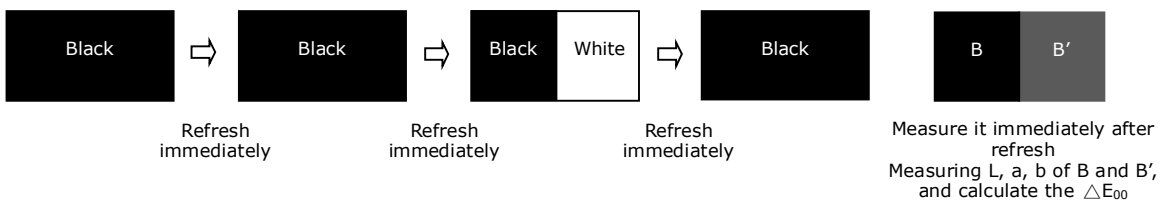

Table 6-3 Measurement of Ghosting

| Item | Rating | | |
|----------------------------|--------|------|------|
| | Min. | Typ. | Max. |
| Test 1 ΔE^{*ab} | - | - | 2 |
| Test 2 ΔE^{*ab} | - | - | 2 |

Note: Panel is driven by PDI waveform without masking film and optical measurement by CM-700D with D65 light source and SCE mode.

7 Packing

Figure 7-1 Packing Diagram

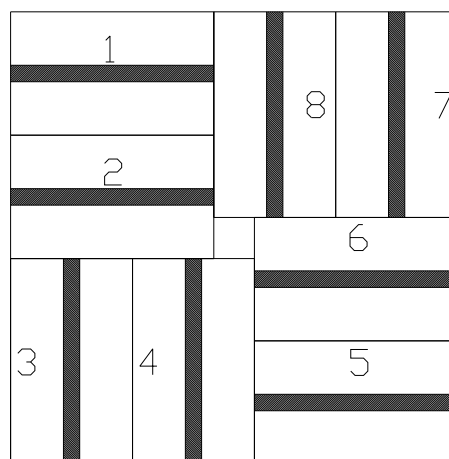
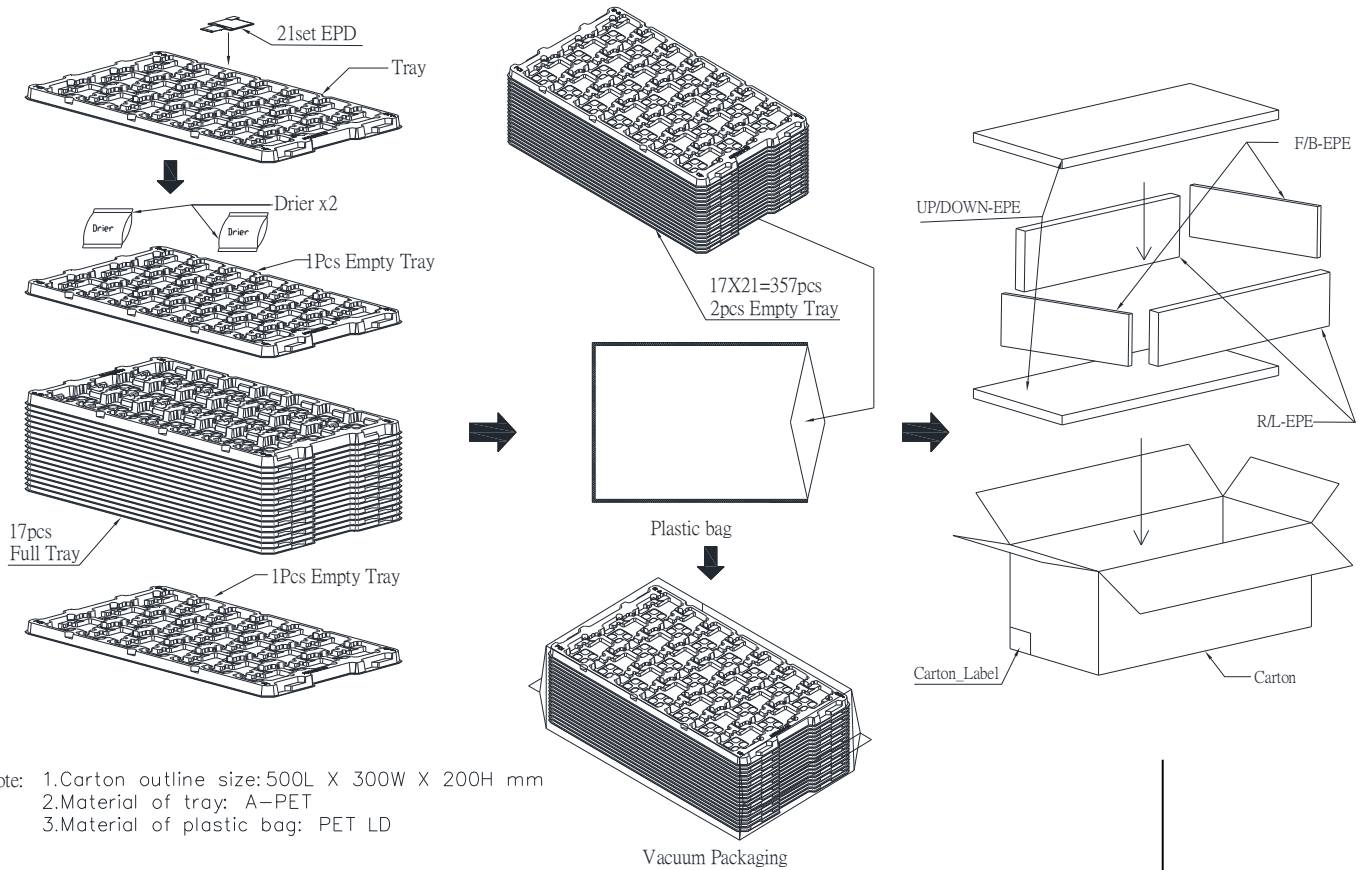

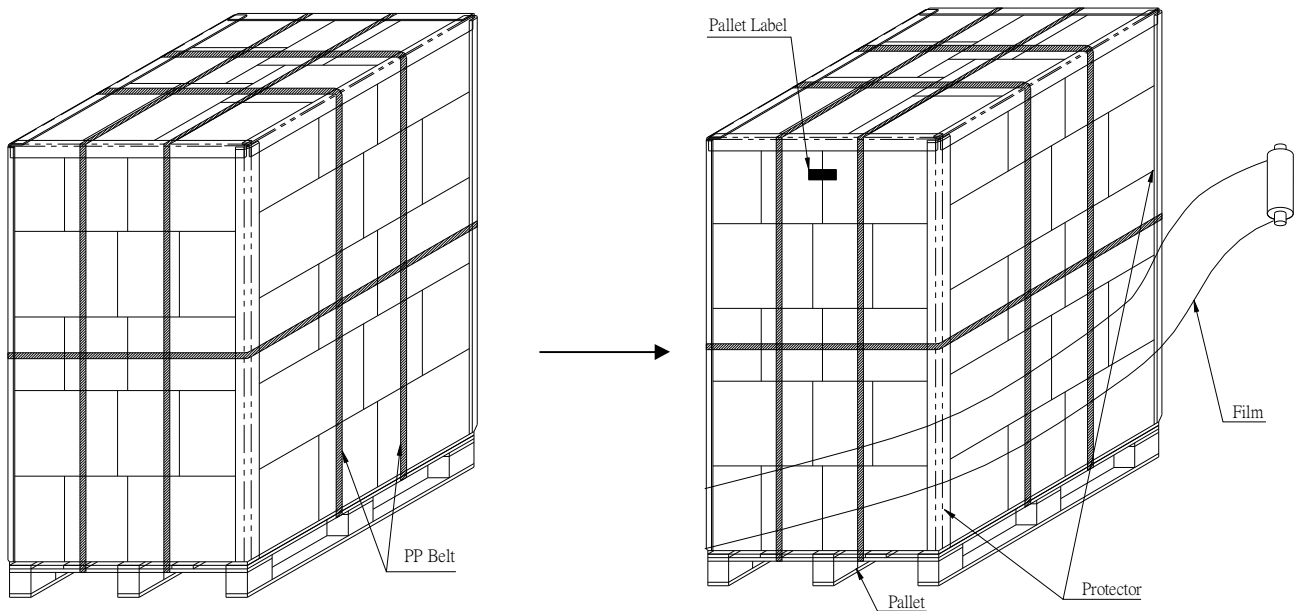

357(pcs) x 40(BOX)=14,280pcs

| | |
|--------|--------------|
| | 1.9" EPD BOX |
| N.W. : | 1.25 Kg |
| G.W. : | 4.62 Kg |

Sea / Land / Air Transportation

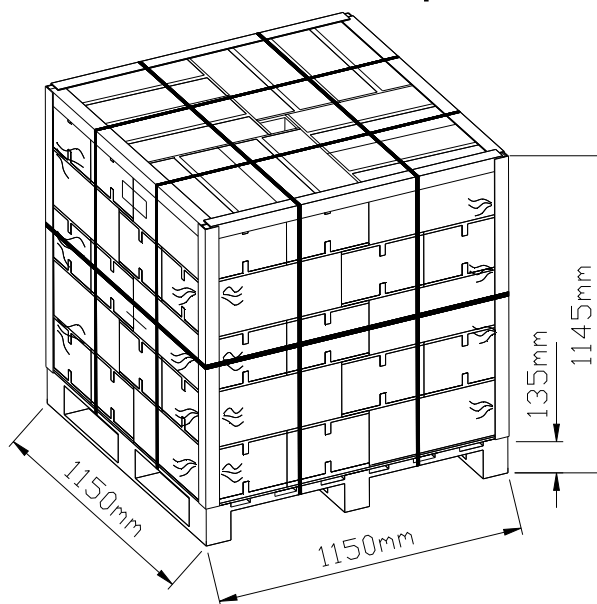

8 Precautions

- (1) The EPD Panel / Module is manufactured from fragile materials such as glass and plastic, and may be broken or cracked if dropped. Please handle with care. Do not apply force such as bending or twisting to the EPD panel during assembly. Please put on gloves to handle EPD to avoid slash.
- (2) It is recommended to assemble or install EPD panels in a clean working area. Dust and oil may cause electrical shorts or degrade / scratch / dent the protection sheet film.
- (3) Do not apply pressure to the EPD panel in order to prevent damaging it.
- (4) Do not connect or disconnect the interface connector while the EPD panel is in operation.
- (5) Please support the bezel with your finger while connecting the interface cable such as the FPC.
- (6) Do not stack the EPD panels / Modules.
- (7) Do not press the FPC on the glass edge or Pull FPC up / down to 90°.
- (8) Do not touch the FPC lead connector.
- (9) Do not touch IC bonding area. It may scratch TFT lead or damage IC function.
- (10) Wear a Wrist Strap (Grounding connect) when handling and during assembly. Semiconductor devices are included in the EPD Panel / Module and they should be handled with care to prevent any electrostatic discharge (ESD). (An Ion Fan may be needed in assembly operation to reduce ESD risk.)
- (11) Keep the EPD Panel / Module in the specified environment and original packing boxes when storage in order to avoid scratching and keep original performance.
- (12) Do not disassemble or reassemble the EPD Panel / Module.
- (13) Use a soft dry cloth without chemicals for cleaning. Please don't press hard for cleaning because the surface of the protection sheet film is very soft and without hard coating. This behavior would make dent or scratch on protection sheet.
- (14) Please be mindful of moisture to avoid its penetration into the EPD panel, which may cause damage during operation.
- (15) It's low temperature operation product. Please be mindful the temperature different to make frost or dew on the surface of EPD panel. Moisture may penetrate into the EPD panel because of frost or dew on surface of EPD panel, and makes EPD panel damage.
- (16) If the EPD Panel / Module is not refreshed every 24 hours, a phenomena known as "Ghosting" or "Image Sticking" may occur. It is recommended that customer refreshed the ESL / EPD Tag every 24 hours in use case. It is recommended that customer ships or stores the ESL / EPD Tag with a completely white image to avoid this issue.
- (17) High temperature, high humidity, sunlight or fluorescent light may degrade the EPD panel's performance. Please do not expose the unprotected EPD panel to high temperature, high humidity, sunlight, or fluorescent for long periods of time.

- (18) The label ink used for marking the Panel ID number is erased easily by solvent. Please avoid using solvent to clean the EPD panel. It would be concerned for RMA.
- (19) The EPD Panel / Module is vacuum packed with white image for shipment and storage.
- (20) Before approved by PDI and customer, products and product specifications may be subject to change without notice. Confirm that you have received the latest product standards or specifications before final design, purchase or use.
- (21) PDI makes every attempt to ensure that its products are of high quality and reliability. However, contact PDI sales office before using the product in an application that demands especially high quality and reliability or where its failure or malfunction may directly threaten human life or cause risk of bodily injury, such as aerospace, aeronautics, nuclear power, combustion control, transportation, traffic, safety equipment or medical equipment for life support.
- (22) Design your application so that the product is used within the ranges guaranteed by PDI particularly for maximum rating, operating supply voltage range, heat radiation characteristics, installation conditions and other characteristics. PDI bears no responsibility for failure or damage when used beyond the guaranteed ranges. Even within the guaranteed ranges, consider normally foreseeable failure rates or failure modes in semiconductor devices and employ systemic measures such as fail safes, so that the equipment incorporating PDI product does not cause bodily injury, fire or other consequential damage due to operation of the PDI product.
- (23) This product is not designed to be radiation resistant.
- (24) Please keep $R \geq 1.0\text{mm}$ when bend for assembly.

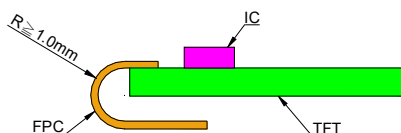

9 Definition of Labels

Figure 9-1 Definition of Model Labels

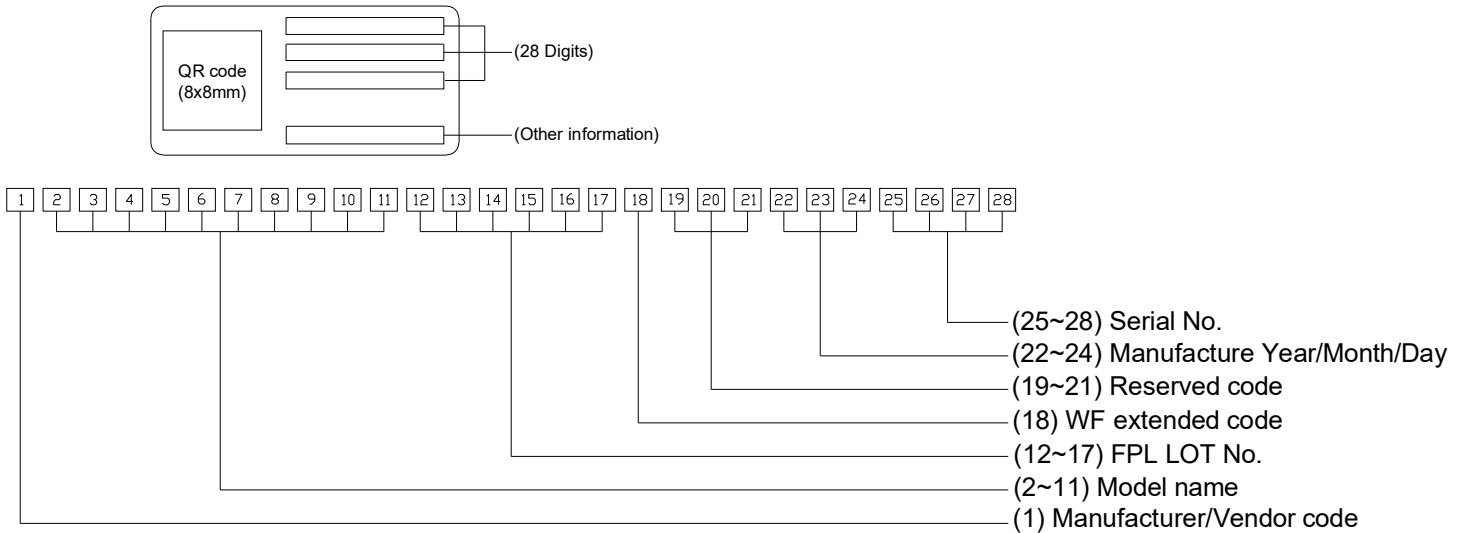
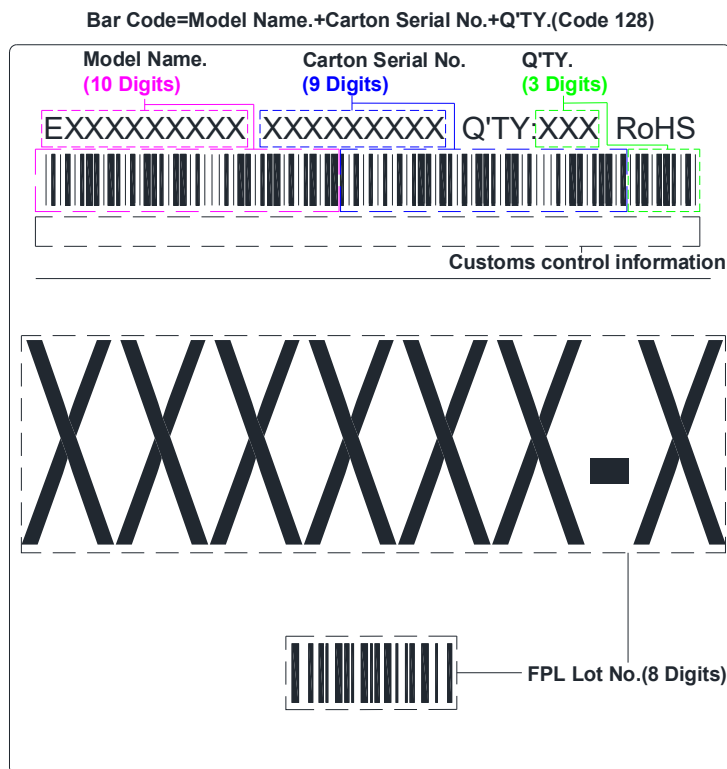

Figure 9-2 Carton Label



Carton Label

Note(1): The digit of No.8 is WF extended code

Figure 9-3 Pallet Label

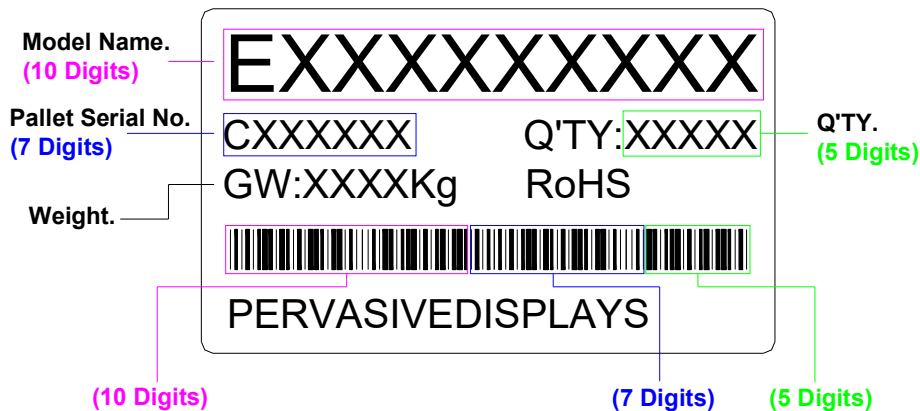

Bar Code=Model Name.+Pallet Serial No.+Q'TY.(22 Digits)

Pallet Label