

# Product Specifications

<b>Customer</b>	<b>STANDARD</b>
<b>Description</b>	<b>2.66" 4-Colors TFT EPD Panel</b>
<b>Model Name</b>	<b>E2266QS0F1</b>
<b>Date</b>	<b>2023/06/09</b>
<b>Doc. No.</b>	<b>1P363-00</b>
<b>Revision</b>	<b>01</b>

<b>Customer Approval</b>	
<b>Date</b>	
The above signature represents that the product specifications, testing regulation, and warranty in the specifications are accepted	

	<b>Design Engineering</b>		
	<b>Approval</b>	<b>Check</b>	<b>Design</b>
			

4F, No. 28, Chuangye Rd., Tainan Science Park, Tainan City 74144, Taiwan (R.O.C.)

Tel: +886-6-279-5399 Fax: +886-6-505-5300

## Copyright

Pervasive Displays Incorporated All rights reserved.

This document is the exclusive property of Pervasive Displays Inc. (PDI) and shall not be reproduced or copied or transformed to any other format without prior permission of PDI. (PDI Confidential)

本資料為龍亭新技股份有限公司專有之財產，非經許可，不得複製、翻印或轉變成其他形式使用。

龍亭新技股份有限公司 Pervasive Displays Inc.

4F, No. 28, Chuangye Rd., Tainan Science Park, Tainan City 74144, Taiwan (R.O.C.)

Tel: +886-6-279-5399

<http://www.pervasivedisplays.com>

PDI Confidential

## Table of Contents

Revision History.....	6
Glossary of Acronyms .....	7
1 General Description.....	8
1.1 Overview .....	8
1.2 Features .....	8
1.3 Applications .....	8
1.4 General Specifications.....	9
2 Absolute Maximum Ratings .....	11
2.1 Absolute Ratings of Environment .....	11
2.2 Reliability Test Item.....	12
2.3 Product Warranty .....	12
3 Electrical Characteristics .....	13
3.1 Absolute Maximum Ratings of Panel .....	13
3.2 Recommended Operation Conditions of Panel.....	13
4 Application Circuit Block Diagram .....	15
5 Terminal Pin Assignment & Reference Circuit.....	16
5.1 Input Terminal Pin Assignment .....	16
5.2 Reference Circuit.....	18
6 Optical Characteristics .....	19
6.1 Test Conditions .....	19
6.2 Optical Specifications.....	19
7 Packing .....	22
8 Precautions .....	24
9 Definition of Labels .....	26

## List of Figures

Figure 1-1	EPD Drawing .....	10
Figure 3-1	Test Pattern of Panel .....	14
Figure 3-2	Image Update Current Profile .....	14
Figure 3-3	Current Measurement .....	15
Figure 4-1	Application Circuit Block Diagram .....	15
Figure 5-1	EPD Reference Circuit .....	18
Figure 6-1	Optical measurement.....	20
Figure 6-2	Definition of Viewing Angle to Measure Contrast Ratio .....	21
Figure 7-1	Packing Diagram .....	22
Figure 9-1	Definition of Model Labels .....	26
Figure 9-2	Carton Label.....	26
Figure 9-3	Pallet Label .....	26

PDI Confidential

## List of Tables

Table 1-1	General Specification .....	9
Table 2-1	Absolute Ratings of Environment .....	11
Table 2-2	Reliability Test Items .....	12
Table 3-1	Absolute Maximum Ratings of Panel .....	13
Table 3-2	Recommended Operation Conditions of Panel .....	13
Table 5-1	Input Connector Specification .....	16
Table 5-2	Terminal Pin Assignment .....	16
Table 6-1	Optical Measurement Conditions.....	19
Table 6-2	Optical Measurement with D65 light source.....	19

PDI Confidential

**Revision History**

Version	Date	Page (New)	Section	Description
01	2023/06/09	All	All	Product specification first issued.
<p style="font-size: 48px; opacity: 0.2; transform: rotate(-30deg);">PDI Confidential</p>				

## Glossary of Acronyms

EPD	Electrophoretic Display (e-Paper Display)
EPD Panel	EPD
EPD Module	EPD with TCon board
TCon	Timing Controller
TFT	Thin Film Transistor
MCU	Microcontroller Unit
FPC	Flexible Printed Circuit
FPL	Front Plane Laminate
SPI	Serial Peripheral Interface
COG	Chip on Glass
IIS	Incoming Inspection Standard
ISTA	International Safe Transit Association
PDI	Pervasive Displays Incorporated

PDI Confidential

## 1 General Description

### 1.1 Overview

This is a 4-Colors 2.66" a-Si, active matrix TFT, Electronic Paper Display (EPD) panel. The panel is capable to show Black, White, Red & Yellow. The panel has high resolution (125dpi) that it is able to easily display fine patterns. Due to its bi-stable nature, the EPD panel requires very little power to update and needs no power to maintain an image.

### 1.2 Features

- a-Si TFT active matrix Electronic Paper Display (EPD)
- Three colors support: White, Black, Red, Yellow
- Resolution: 296x 152
- Ultra-low power consumption
- Super Wide Viewing Angle - near 180°
- Extra thin & light
- SPI interface
- RoHS compliant

### 1.3 Applications

- Electronic shelf label (ESL)
- Reusable container
- Badge

PDI Confidential



**1.4 General Specifications**

**Table 1-1 General Specification**

Item	Specification	Unit	Note
Outline Dimension	71.82(H) x 36.3(V) x 0.85t	mm	(1)
Active Area	60.088(H) x 30.704(V)	mm	
Driver Element	a-Si TFT active matrix	-	
Pixel Number	296 x 152	pixel	
Pixel Pitch	0.203 x 0.202(125dpi)	mm	
Pixel Arrangement	Vertical stripe	-	
Display Colors	Black/White/Red/Yellow	-	
Surface Treatment	Anti-Glare	-	
Weight	4.8 ± 1	g	

Note (1): Not including the FPC.

PDI Confidential

**Figure 1-1 EPD Drawing**

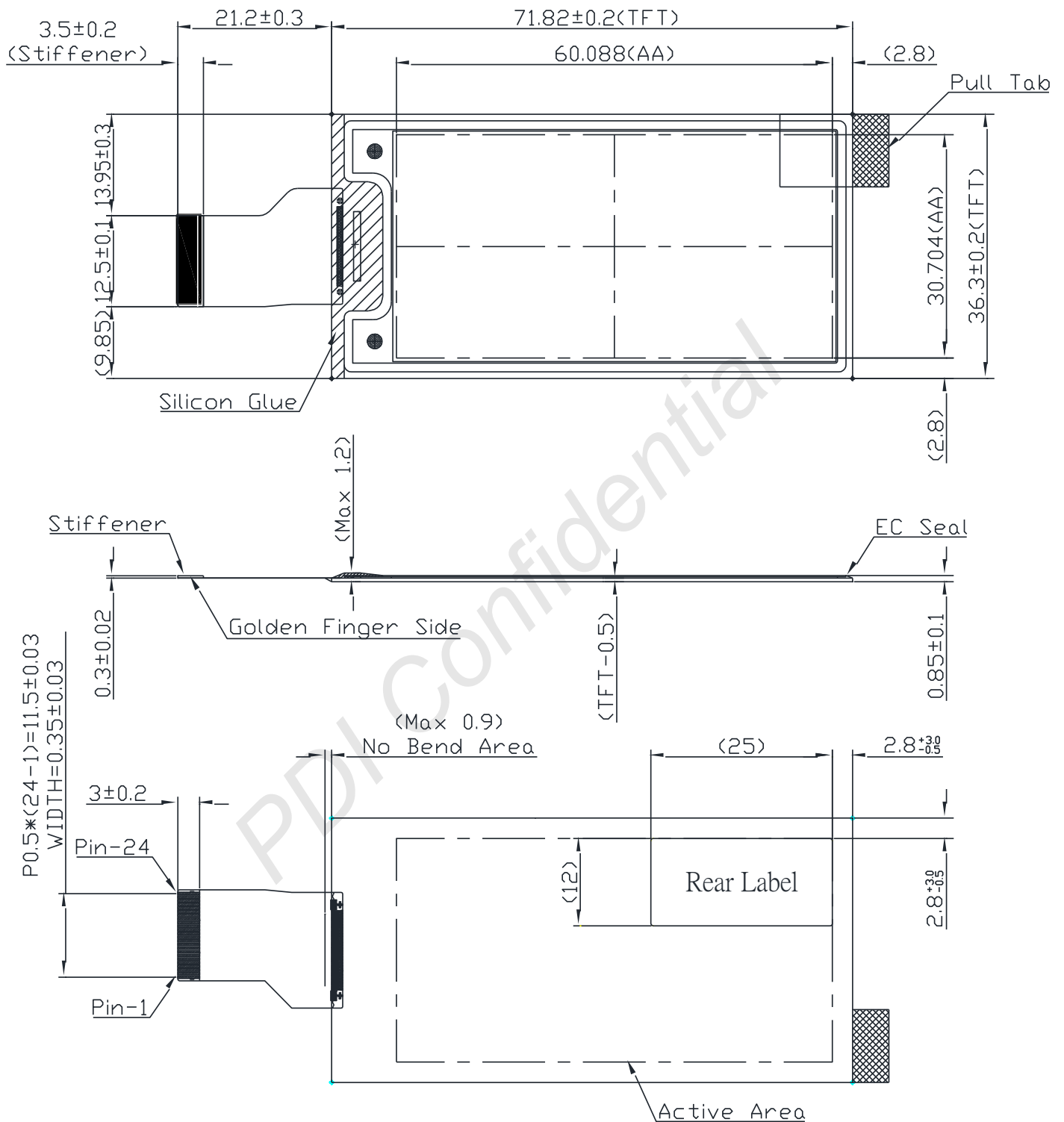

**General tolerance:  $\pm 0.3\text{mm}$**

## 2 Absolute Maximum Ratings

### 2.1 Absolute Ratings of Environment

**Table 2-1 Absolute Ratings of Environment**

Item	Symbol	Value		Unit	Note
		Min.	Max.		
Storage Temperature	T <sub>ST</sub>	-25	+60	°C	(1),(3)
Storage Humidity	H <sub>ST</sub>	40	80	%RH	(1),(3)
Operating Ambient Temperature	T <sub>OP</sub>	0	+40	°C	(1),(2),(3)
Operating Ambient Humidity	H <sub>OP</sub>	40	80	%RH	(1),(2),(3)
Optimal Storage Temperature	T <sub>OST</sub>	-10	+35	°C	(1),(3)
Optimal Storage Humidity	H <sub>OST</sub>	45	65	%RH	(1),(3)

Note (1):

- (a) 80 %RH Max. ( $T_a \leq 40\text{ }^\circ\text{C}$ ), 40%RH Min. ( $T_a \leq 60\text{ }^\circ\text{C}$ ) where  $T_a$  is ambient temperature.
- (b) No condensation and no frost in absolute ratings of Environment.

Note (2): The temperature of panel display surface area should be 0 °C Min. and 40°C Max. Refresh time depends on operating temperature.

Note (3): E Ink Material is Moisture and UV sensitive. The absolute rating operating environments describes the boundary conditions for updating the display while the absolute rating storage environment describe the boundary conditions for a display not updating. While displays are rated to perform according to specification for the warranty period at the absolute specified operating environment, the better the storage condition, the better the E Ink displays will perform. Similar to other moisture and UV sensitive components, we recommend that our displays be stored in temperature and humidity control environments, and whenever possible, under above defined Optimal Storage Condition, away from sunlight, to optimize their performance.

Note (4): The performance of EPD may be degraded under sunlight. Please customer consults PDI if customer wants to use EPD under sunlight.

## 2.2 Reliability Test Item

**Table 2-2 Reliability Test Items**

Item	Test Condition	Remark
High Temperature Operation	40 °C/ 30 %RH for 240h	(1) (2)
Low Temperature Operation	0 °C for 240h	(1) (2)
High Temperature/Humidity Operation	40 °C / 80%RH for 240h	(1) (2)
High Temperature Storage	60 °C/ 40 %RH for 240h	(1)(2)(3)
Low Temperature Storage	-25 °C for 240h	(1)(2)(3)
High Temperature/Humidity Storage	60 °C / 80% RH for 240h	(1)(2)(3)
Thermal Cycles ( Non-operation )	1 Cycle:-25°C/30min → 60°C/30min, for 100 Cycles	(1)(2)(3)
Package Drop Test	Drop from 97cm. ( ISTA ) 1 corner, 3 edges, 6 sides. One drop for each.	(1)(2)(3)
Package Random Vibration Test	1.15Grms, 1Hz ~ 200Hz. ( ISTA )	(1)(2)(3)

Note (1): No condensation and no frost during test. End of test, function, mechanical, and optical shall be satisfied.

Note (2): The test result and judgment are based on PDI's 1bit driving waveform, driving fixture and driving system.

Note (3): Stay white pattern for storage and non-operation test.

## 2.3 Product Warranty

Warranty conditions have to be negotiated between PDI and individual customers. PDI provides 13months warranty for all products which are purchased from PDI.

### 3 Electrical Characteristics

#### 3.1 Absolute Maximum Ratings of Panel

**Table 3-1 Absolute Maximum Ratings of Panel**

Parameter	Symbol	Value		Unit	Note
		Min	Max		
Supply Voltage	$V_{DD}, V_{DDIO}$	-0.5	6.0	V	
Ground	GND	-		-	Connect to Ground

$T_a = 25 \pm 2 \text{ }^\circ\text{C}$

#### 3.2 Recommended Operation Conditions of Panel

**Table 3-2 Recommended Operation Conditions of Panel**

Parameter		Symbol	Value			Unit	Note
			Min	Typ	Max		
VDDIO, VDDA operation voltage		$V_{DDIO}, V_{DDA}$	2.4	3.0	3.6	V	$V_{DDIO}, V_{DD}$ must be stable
Input Voltage	High	$V_{IH}$	$0.7 * V_{DDIO}$	-	$V_{DDIO}$	V	$V_{DDIO}=V_{DD}$
	Low	$V_{IL}$	0	-	$0.3 * V_{DDIO}$	V	
Output Voltage	High	$V_{OH}$	$V_{DDIO} - 0.4$	-	$V_{DDIO}$	V	$V_{DDIO}=V_{DD}, I_{OH}=100\mu\text{A}$
	Low	$V_{OL}$	0	-	0.4	V	$V_{DDIO}=V_{DD}, I_{OL}=-100\mu\text{A}$
Input Current (Standard price/Snow noise)		$I_{DD}$	-	3.4/ 4.4	-	mA	(1),(2),(3)
Peak Current		$I_{PEAK}$	-	22.6	-	mA	

$T_a = 25 \pm 2 \text{ }^\circ\text{C}$

Note (1):

**Figure 3-1 Test Pattern of Panel**



Standard Price

Snow noise

These currents are tested with PDI test jig.

Note (2):

$$V_{DDIO} = V_{DDA} = 3.0V$$

**Figure 3-2 Image Update Current Profile**

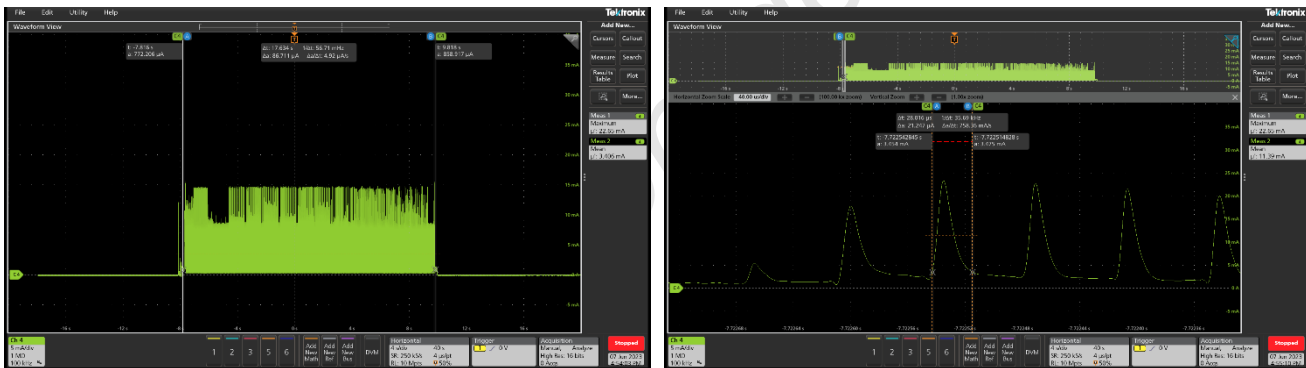

Standard Price

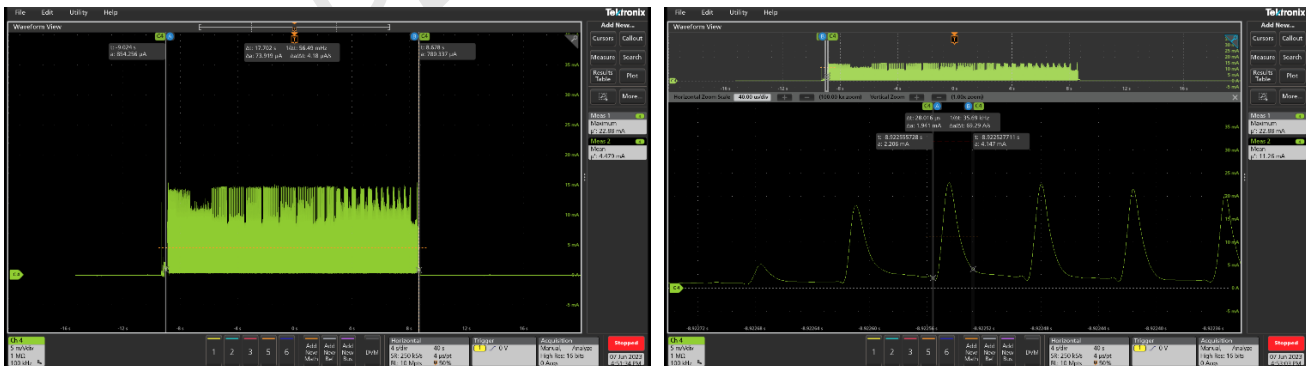

Snow noise

$T_a = 25 \pm 2 \text{ } ^\circ\text{C}$

Note (3):  $I_{DD}$ : The current of  $V_{DD} + V_{DDIO}$ .

$I_{CC}$ : The current of  $V_{CC}$  (EPD Boost Circuit).

Figure 3-3 Current Measurement

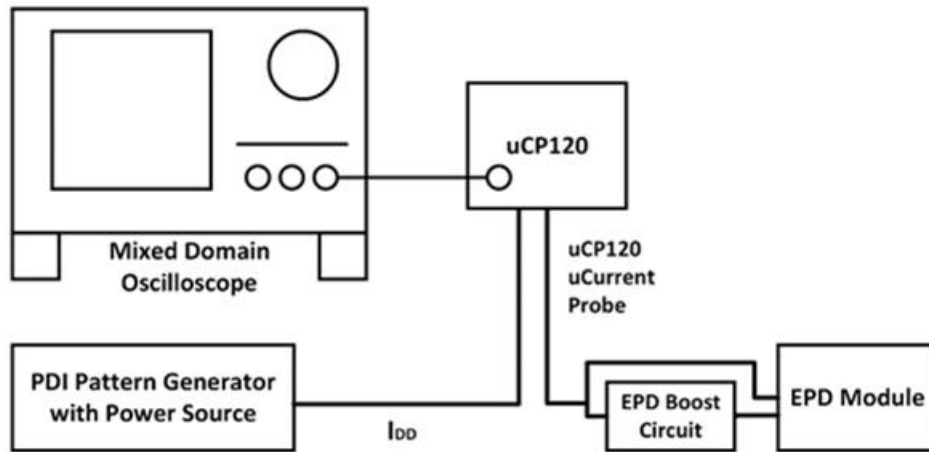

\*Set oscilloscope filter > 200MHz and record length to 10M points.

## 4 Application Circuit Block Diagram

Figure 4-1 Application Circuit Block Diagram

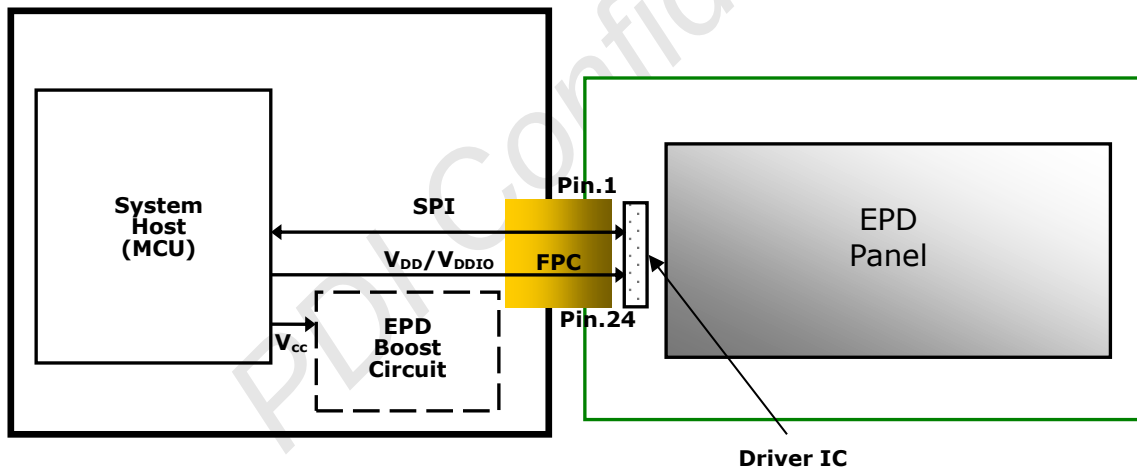

## 5 Terminal Pin Assignment & Reference Circuit

### 5.1 Input Terminal Pin Assignment

**Table 5-1 Input Connector Specification**

Item	Pin numbers	Pitch (mm)	Connector	Note
Golden Finger	24	0.5	HRS FH34SRJ24S or STARCONN 6700S24 or Compatible	(1)

Note (1): HRS FH34SRJ 24S is 24-pins connectors. The 24 pins are used to connect FPC pads of EPD. Please refer PDI demo kit for detailed connection.

**Table 5-2 Terminal Pin Assignment**

No.	Signal	Type	Connected to	Function
1	NC	-	-	Not connected
2	GDR	O	Power MOSFET Driver control	This pin is the N-Channel MOSFET Gate Drive Control.
3	RESE	I	Booster Control Input	This pin is the Current Sense Input for the Control Loop.
4	NC	-	-	Not connected
5	VDHR	C	Capacitor	This pin is the red driving voltage. A stabilizing capacitor should be connected between VDHR and GND.
6	NC	-	-	-
7	NC	-	-	-
8	BS	I	VSS	This pin is setting panel interface.
9	BUSY	O	Device Busy Signal	This pin is Busy state output pin. When Busy is Low, the operation of the chip should not be interrupted, and Command should not be sent.
10	RES	I	System Reset	This pin is reset signal input. Active Low.
11	D/C	I	VDDIO or VSS	This pin is Data/Command control.



No.	Signal	Type	Connected to	Function
12	CS#	I	VDDIO or VSS	This pin is the chip select.
13	SCL	I	Data Bus	Serial communication clock input.
14	SDA	I	Data Bus	Serial communication data input/output.
15	VDDIO	P	Power Supply	Power for interface logic pins& I/O. It should be connected with VDDIO.
16	VDDA	P	Power Supply	Power Supply for the chip.
17	GND	P	Ground	Ground
18	VDDD	C	Capacitor	Internal regulator output A capacitor should be connected between VDDD and VSS.
19	NC	-	-	-
20	VDH	C	Capacitor	This pin is the Positive Source driving voltage. A stabilizing capacitor should be connected between VDH and GND.
21	VGH	C	Capacitor	This pin is the Positive Gate driving voltage. A stabilizing capacitor should be connected between VGH and GND.
22	VDL	C	Capacitor	This pin is the Negative Source driving voltage. A stabilizing capacitor should be connected between VSL and GND.
23	VGL	C	Capacitor	This pin is the Negative Gate driving voltage. A stabilizing capacitor should be connected between VGL and GND.
24	VCOM	C	Capacitor	This pin is the VCOM driving voltage. A stabilizing capacitor should be connected between VCOM and GND.

Note:

Type: I: Input      C: Capacitor  
          O: Output     P: Power

## 5.2 Reference Circuit

Figure 5-1 EPD Reference Circuit

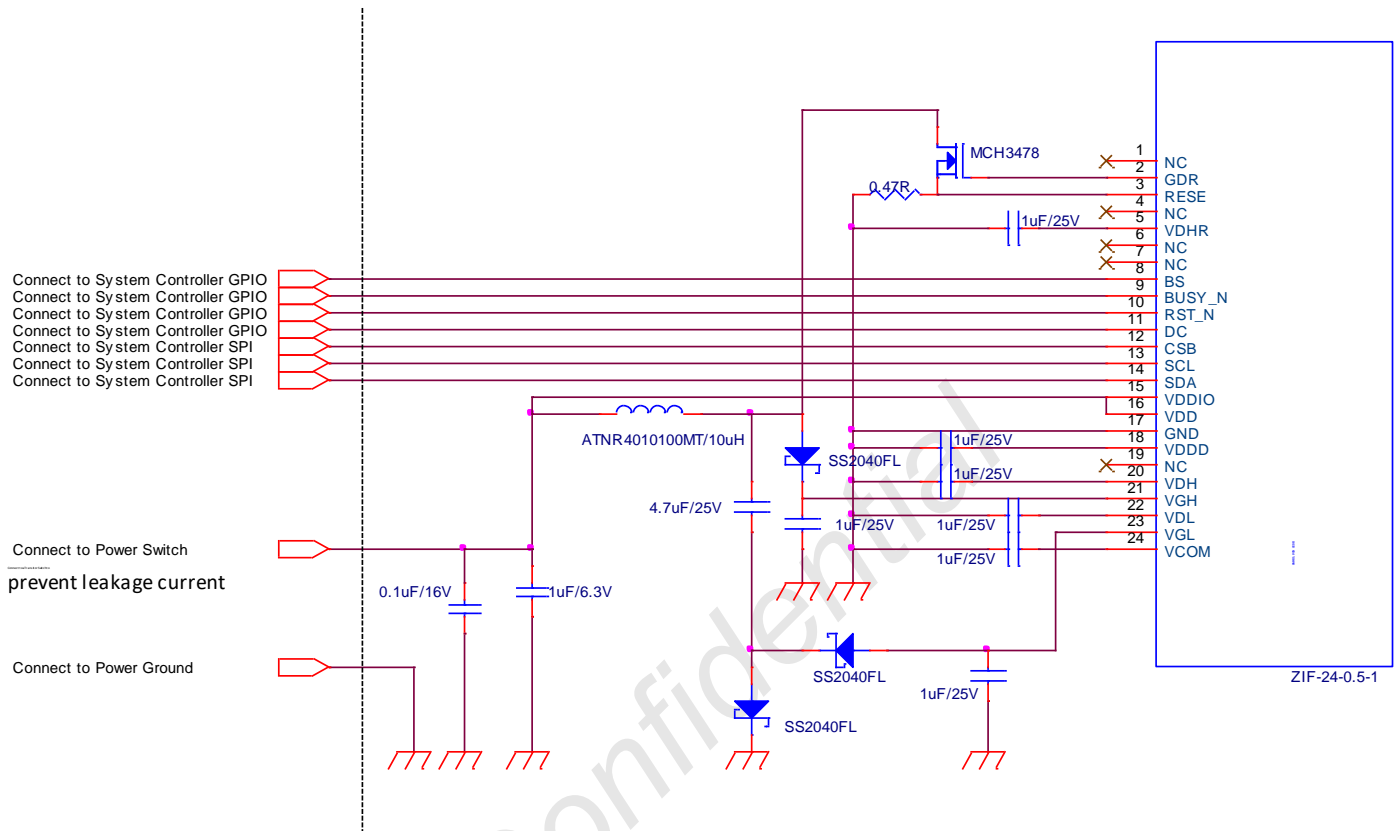

Type	Part	Vendor
Inductor	10uH ATNR4010100MT +/-20% 0.8A	ARLITECH
Transistor	MCH3478 SOT-23 N-Channel 30V/2A	ON Semiconductor
Diode	SS2040FL SOD-123FL	PANJIT

Note:

- (1) MCH3478 (ON Semiconductor) is a N-Channel Power MOSFET. The specification of selection criteria is  $R_{DS} < 235\text{m ohm}$  (the lower the better),  $V_{DSS} = 30\text{V}$ ,  $V_{GS} = 2.5\text{V}@I_D = 0.5\text{A}$ .
- (2) SS2040FL is a Schottky diode needs the  $V_f$  as lower as possible, 0.2 to 0.4V and the repetitive peak reverse voltage  $> 25\text{V}$ .

## 6 Optical Characteristics

### 6.1 Test Conditions

**Table 6-1 Optical Measurement Conditions**

Item	Symbol	Value	Unit
Ambient Temperature	Ta	25±2	°C
Ambient Humidity	Ha	50±10	%RH
Supply Voltage	V <sub>DD</sub> , V <sub>DDIO</sub> , V <sub>DDA</sub>	3.0	V

Note (1): Image is updated with above condition.

### 6.2 Optical Specifications

#### 6.2.1 Optical

**Table 6-2 Optical Measurement with D65 light source**

Item	Color	Symbol	Rating			Unit	Note
			Min.	Typ.	Max.		
Contrast ratio	Black/White	CR	-	22.0	-	-	$\theta_x=\theta_y=0$ (1),(2),(4),(5)
Refresh time	Black/White/Red/Yellow	Tr	-	21	-	sec	(1),(3),(5)
Red state	Red	L*	24.0	26.0	-	-	$\theta_x=\theta_y=0$ (1),(2),(5)
		a*	34.0	37.0	-	-	@ 0°C
		a*	32.0	34.0	-	-	@ 0°C
Yellow state	Yellow	L*	54.0	57.0	-	-	$\theta_x=\theta_y=0$ (1),(2),(5)
		b*	58.0	63.0	-	-	@ 0°C
		b*	55.0	57.0	-	-	@ 0°C
Reflectance	White	R%	-	33.0	-	%	(1),(2),(5)

Note (1): Panel is driven by PDI waveform without masking film and optical measurement by CM-700D with D65 light source and SCE mode.

**Figure 6-1 Optical measurement**

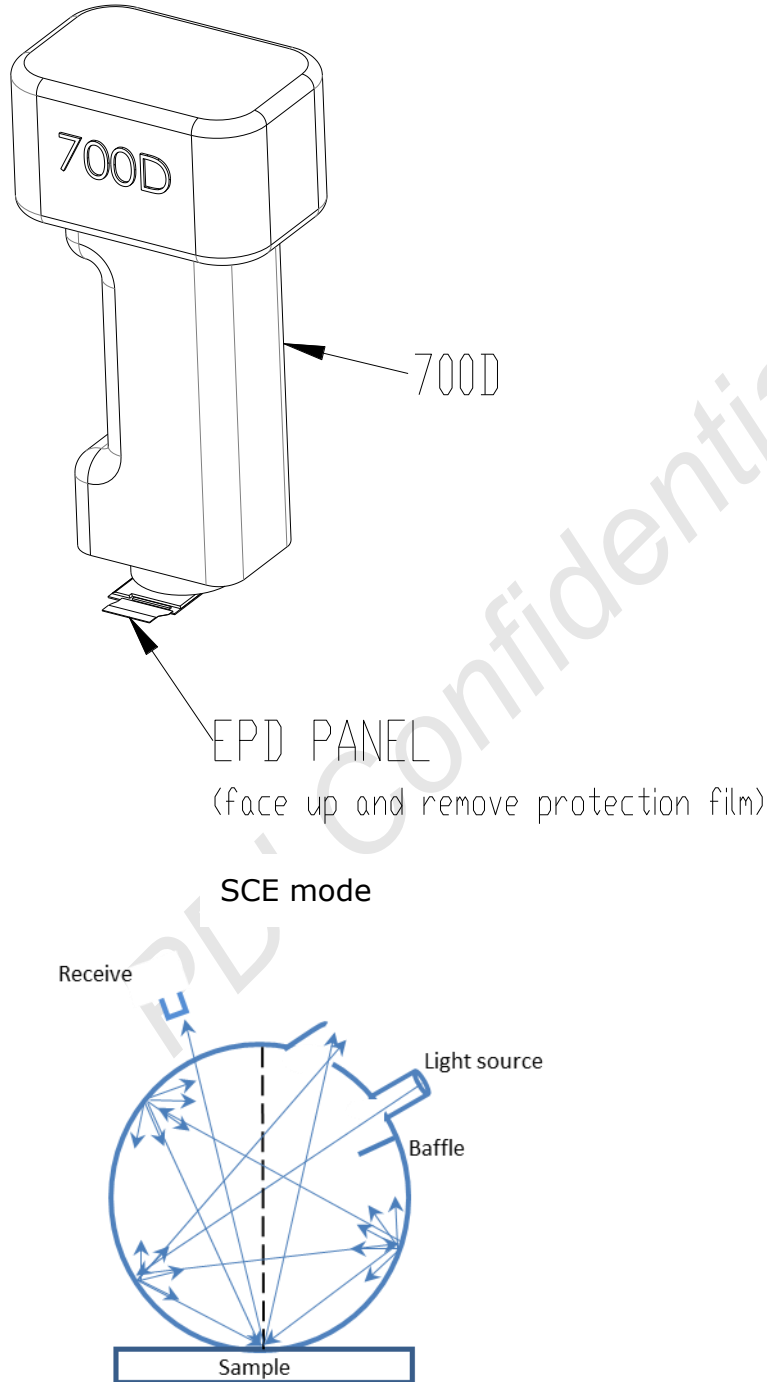

Note (2): Definition of Viewing Angle ( $\theta_x, \theta_y$ ):

**Figure 6-2 Definition of Viewing Angle to Measure Contrast Ratio**

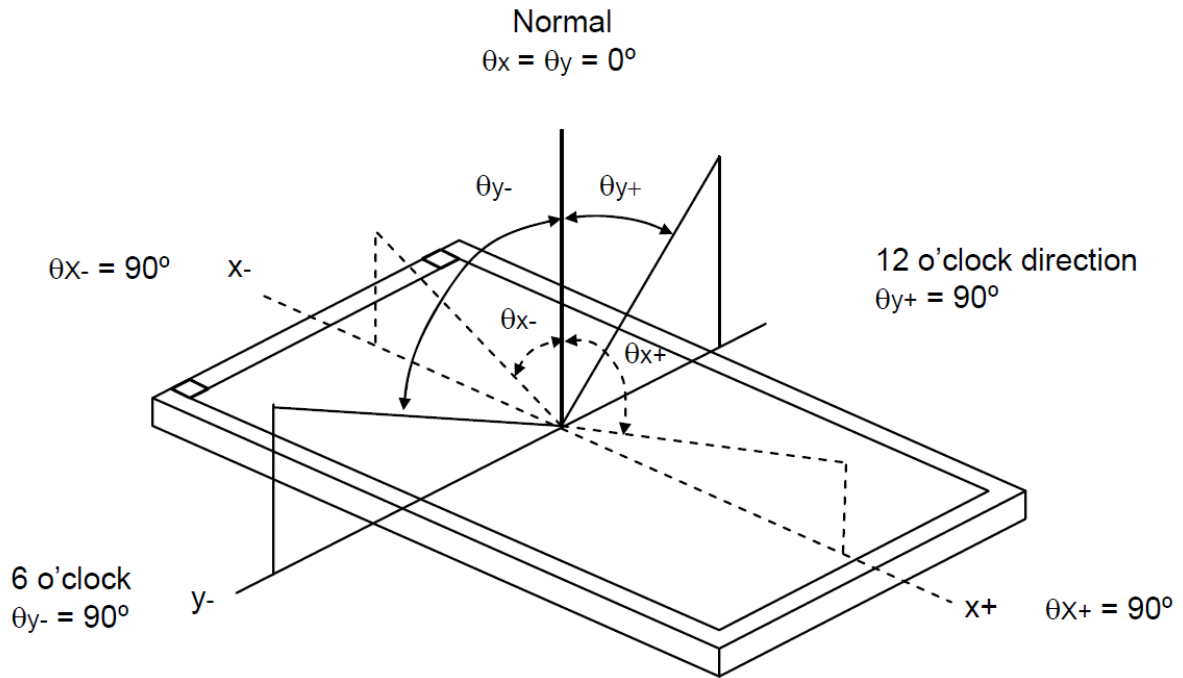

Note (3): Refresh time is the time that e-paper particles move not including the power on and off time. The refresh time is measured at 25°C. The refresh time and contrast ratio vary due to different lot of film, display performance requirements, and ambient temperatures.

Note (4): Contrast ratio (C.R.): The Contrast ratio is calculated by the following expression. C.R. = (R% White)/(R% Black).

Note (5): Optical data is measured at 60 seconds after refresh with PDI's global update procedure.

## 7 Packing

Figure 7-1 Packing Diagram

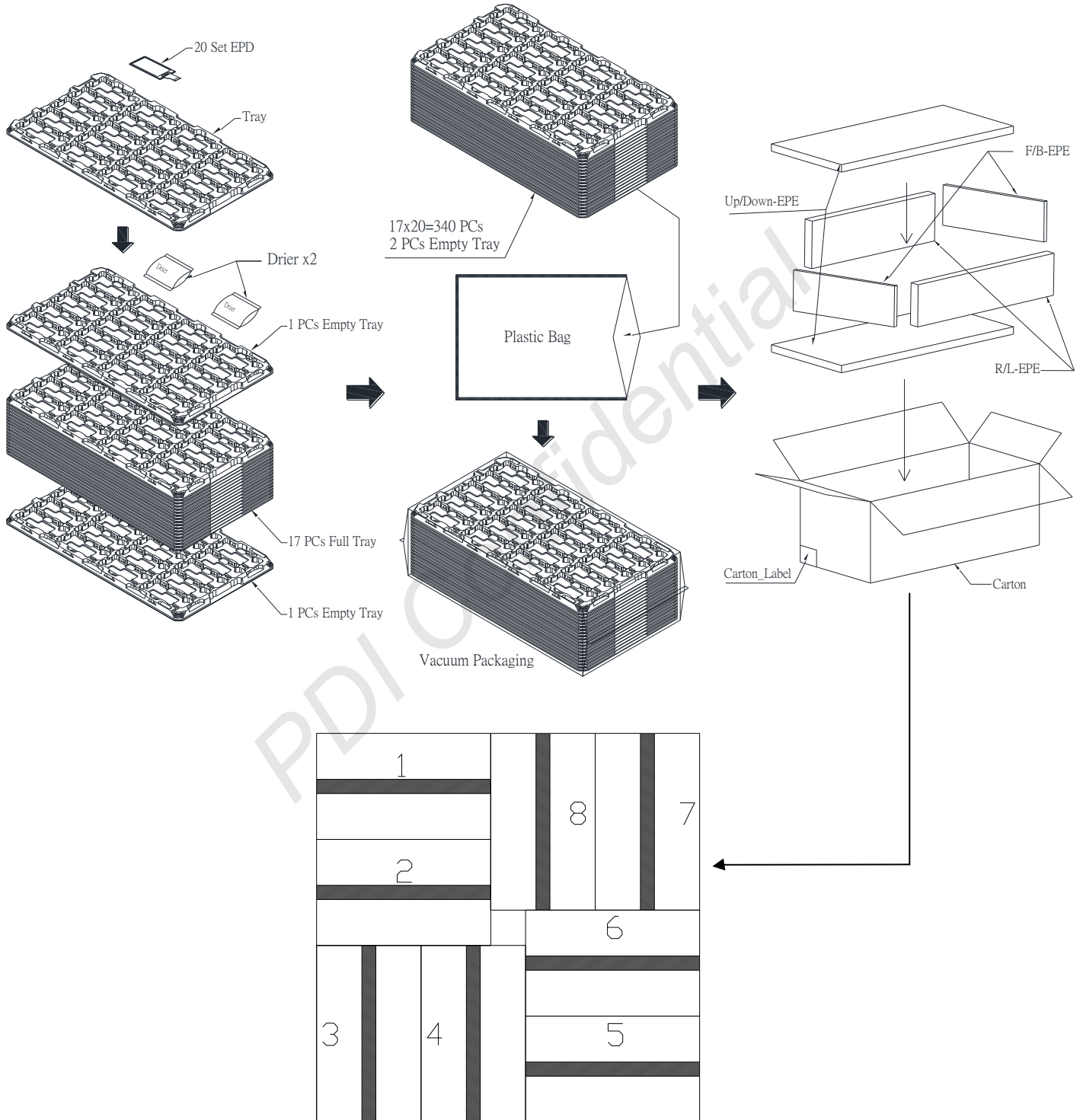

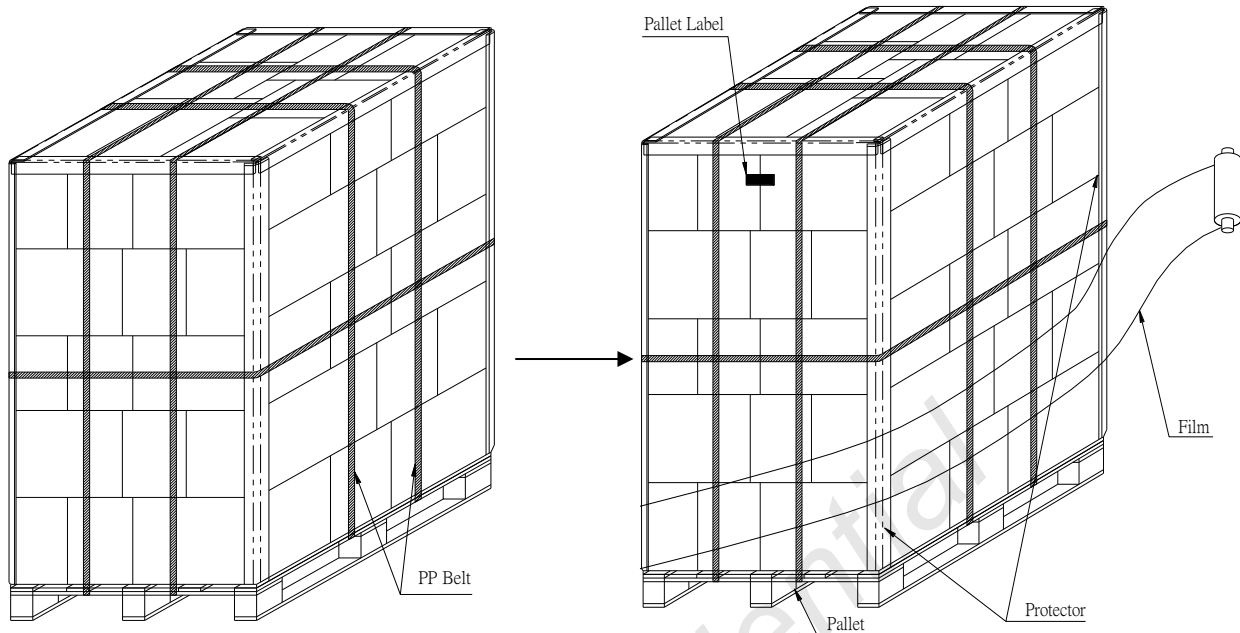

340(pcs)x40(BOX)=13600pcs

	2.66" EPD BOX
N.W. :	1.63Kg
G.W. :	5.00Kg

## Sea / Land / Air Transportation

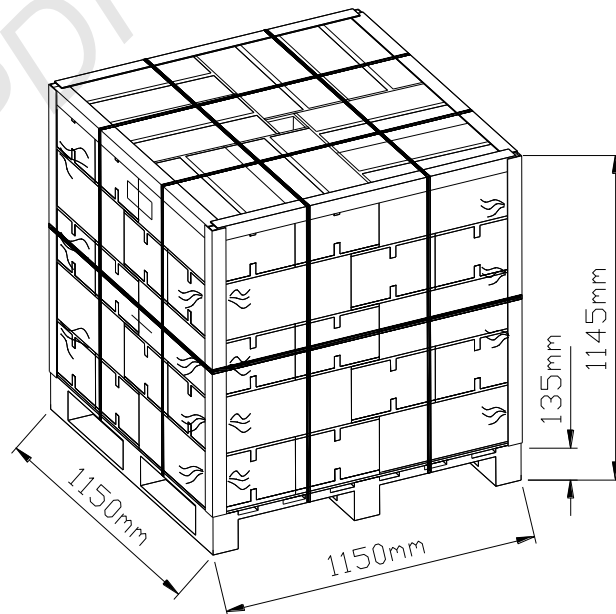



## 8 Precautions

- (1) The EPD Panel / Module is manufactured from fragile materials such as glass and plastic, and may be broken or cracked if dropped. Please handle with care. Do not apply force such as bending or twisting to the EPD panel. Please put on gloves to handle EPD to avoid slash.
- (2) It is recommended to assemble or install EPD panels in a clean working area. Dust and oil may cause electrical shorts or degrade / scratch / dent the protection sheet film.
- (3) Do not apply pressure to the EPD panel in order to prevent damaging it.
- (4) Do not connect or disconnect the interface connector while the EPD panel is in operation.
- (5) Please support as the bezel with your finger while connecting the interface cable such as the FPC.
- (6) Do not stack the EPD panels / Modules.
- (7) Do not press the FPC on the glass edge or Pull FPC up / down to 90°.
- (8) Do not touch the FPC lead connector.
- (9) Do not touch IC bonding area. It may scratch TFT lead or damage IC function.
- (10) Wear a Wrist Strap (Grounding connect) when handling and during assembly. Semiconductor devices are included in the EPD Panel / Module and they should be handled with care to prevent any electrostatic discharge (ESD). (An Ion Fan may be needed in assembly operation to reduce ESD risk.)
- (11) Keep the EPD Panel / Module in the specified environment and original packing boxes when storage in order to avoid scratching and keep original performance.
- (12) Do not disassemble or reassemble the EPD panel.
- (13) Use a soft dry cloth without chemicals for cleaning. Please don't press hard for cleaning because the surface of the protection sheet film is very soft and without hard coating. This behavior would make dent or scratch on protection sheet.
- (14) Please be mindful of moisture to avoid its penetration into the EPD panel, which may cause damage during operation.
- (15) It's low temperature operation product. Please be mindful the temperature different to make frost or dew on the surface of EPD panel. Moisture may penetrate into the EPD panel because of frost or dew on surface of EPD panel, and makes EPD panel damage.
- (16) If the EPD Panel / Module is not refreshed every 24 hours, a phenomena known as "Ghosting" or "Image Sticking" may occur. It is recommended that customer refreshed the ESL / EPD Tag every 24 hours in use case. It is recommended that customer ships or stores the ESL / EPD Tag with a completely white image to avoid this issue
- (17) High temperature, high humidity, sunlight or fluorescent light may degrade the EPD panel's performance. Please do not expose the unprotected EPD panel to high temperature, high humidity, sunlight, or fluorescent for long periods of time.
- (18) The label ink used for marking the Panel ID number is erased easily by solvent. Please avoid using solvent to clean the EPD panel.
- (19) The EPD is vacuum packed.
- (20) Before approved by PDI and customer, products and product specifications may be subject to change without notice. Confirm that you have received the latest product standards or specifications before final design, purchase or use.



- (21) PDI makes every attempt to ensure that its products are of high quality and reliability. However, contact PDI sales office before using the product in an application that demands especially high quality and reliability or where its failure or malfunction may directly threaten human life or cause risk of bodily injury, such as aerospace, aeronautics, nuclear power, combustion control, transportation, traffic, safety equipment or medical equipment for life support.
- (22) Design your application so that the product is used within the ranges guaranteed by PDI particularly for maximum rating, operating supply voltage range, heat radiation characteristics, installation conditions and other characteristics. PDI bears no responsibility for failure or damage when used beyond the guaranteed ranges. Even within the guaranteed ranges, consider normally foreseeable failure rates or failure modes in semiconductor devices and employ systemic measures such as fail safes, so that the equipment incorporating PDI product does not cause bodily injury, fire or other consequential damage due to operation of the PDI product.
- (23) This product is not designed to be radiation resistant.
- (24) Please keep  $R \geq 1.0\text{mm}$  when bend for assembly.

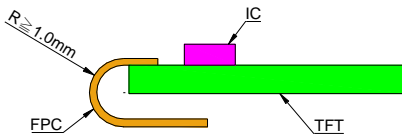

PDI Confidential

## 9 Definition of Labels

Figure 9-1 Definition of Model Labels

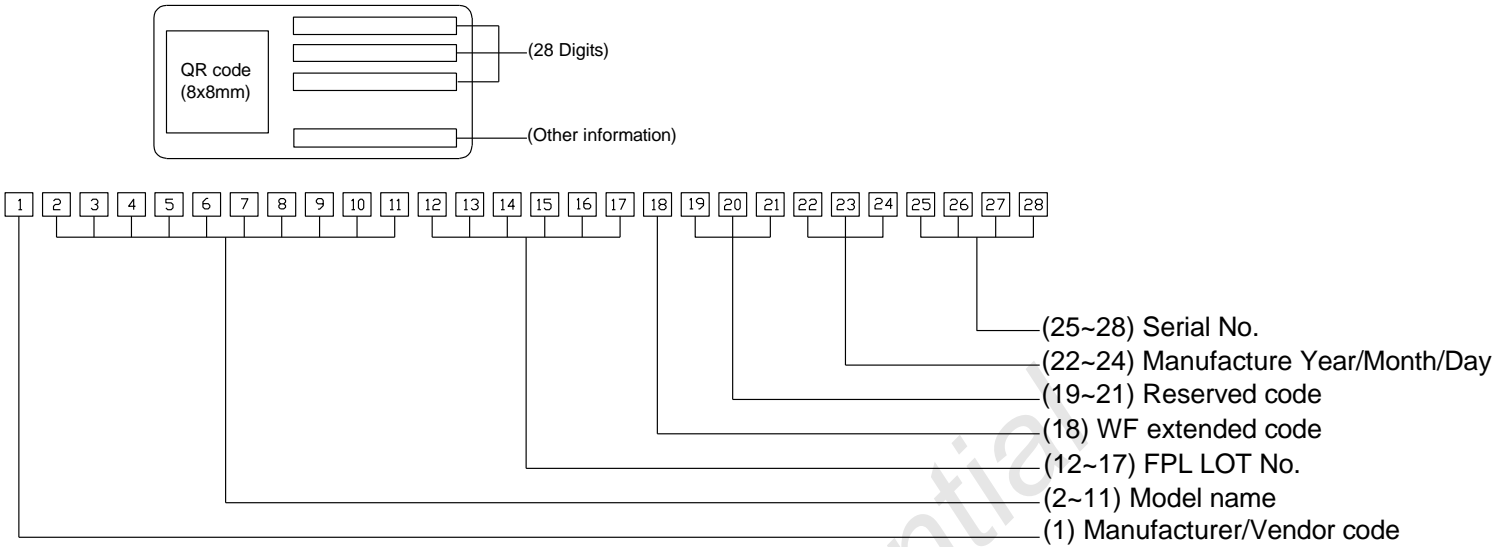
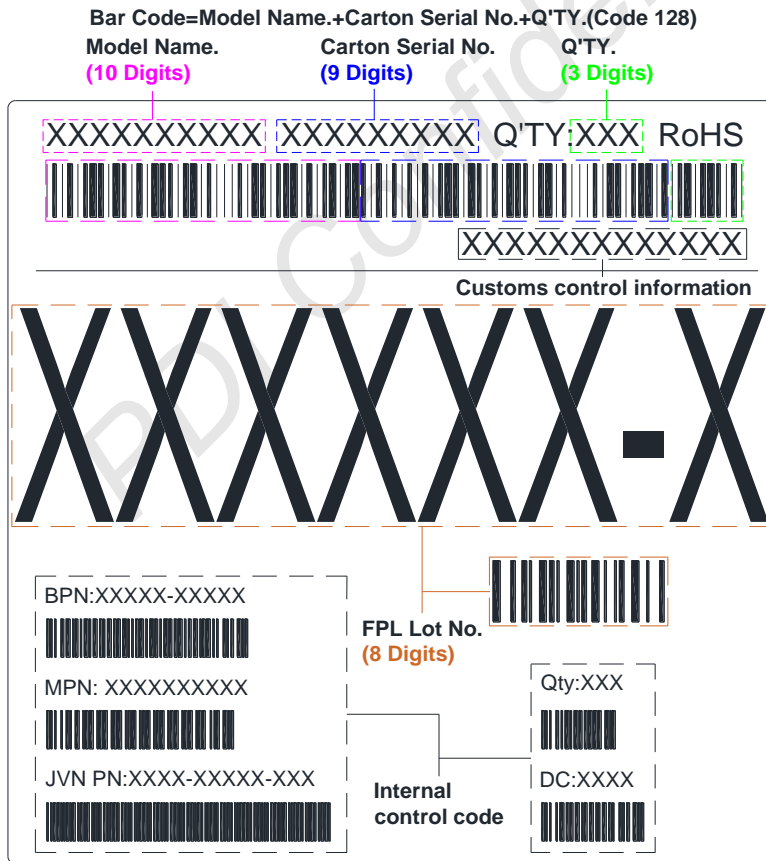

Figure 9-2 Carton Label



Carton Label

Note(1): The digit of FPL Lot No.8 is WF extended code

Figure 9-3 Pallet Label

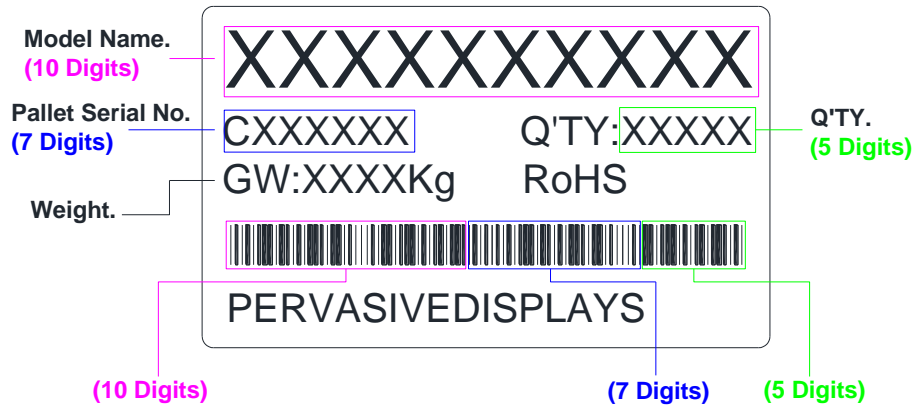

Bar Code=Model Name.+Pallet Serial No.+Q'TY.(22 Digits)

## Pallet Label

PDI Confidential